

310747520900

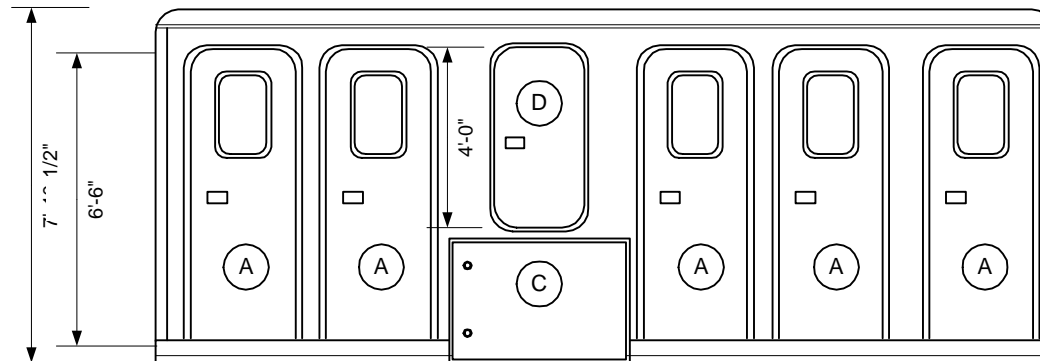

Omega 20 5SS

- (A) 78"x24" radius RH
- (B) 48"x24" radius LH
- (C) 32"x49" top hinge
- (D) 48"x24" radius RH
- (E) 78"x38" radius RH
- (F) 78"x24" radius RH
- (G) 77.5"x35.5" radius LH



- Lowers to ground
- Container S hipable
- Requires 50amp 240vac
- .040 Aluminum Exterior
- 1.5 GPM metered showers
- Hydraulic Electric Disk Brakes
- 250 gallon waste tank capacity
- 250 gallons fresh water storage
- Obscure windows in radius doors
- Heat & Air Conditioned 15,000BTU
- 10000 pound retractable suspension
- 17.5 x 6.75 16 ply 6000# Radial Tires
- All metal and composite construction
- LED 50,000 hour burn lighting and trailer lighting
- Automatic Electric Leveling Jacks 16,000 lb. max
- Rain heated water on demand propane water heater
- Self Pumping to Sewer Tap up to 100 feet w/10' head 1" line

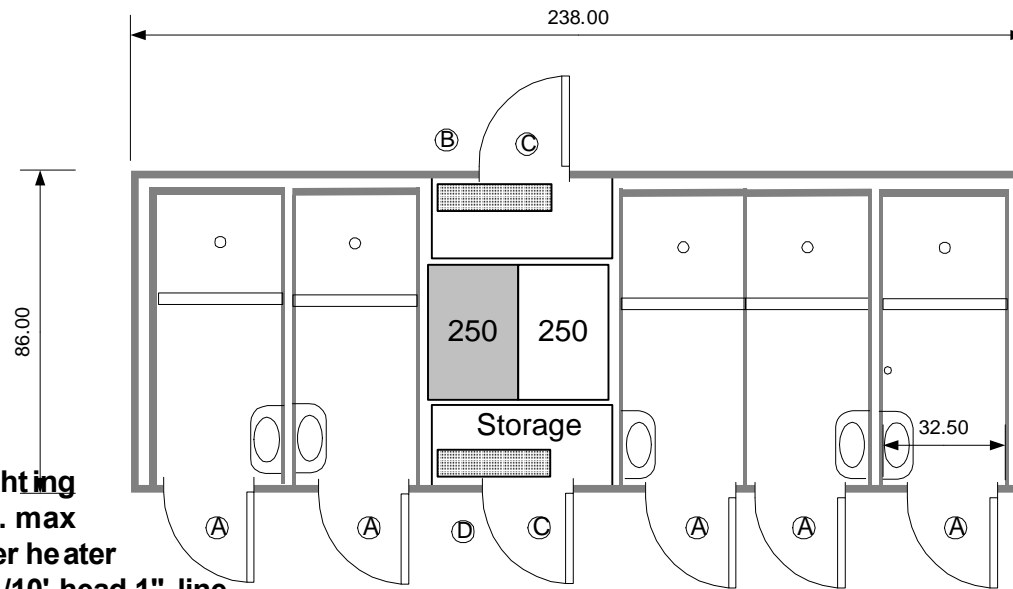

This document is the property of and contains unpublished proprietary information and trade secrets of A.M.S. Global Inc. By accepting possession of the document the recipient agrees to make no copies transcriptions or any use of this document or the information contained herein except as authorized by A.M.S. Global Inc. and further agrees to safe keep this document and return in to A.M.S. Global Inc. upon demand.

Approved by _____



370734610079



Omega 20 5STS

- (A) 78"x24" radius RH
- (B) 48"x24" radius LH
- (C) 32"x49" top hinge
- (D) 48"x24" radius RH
- (E) 78"x38" radius RH
- (F) 78"x24" radius RH
- (G) 77.5"x35.5" radius LH

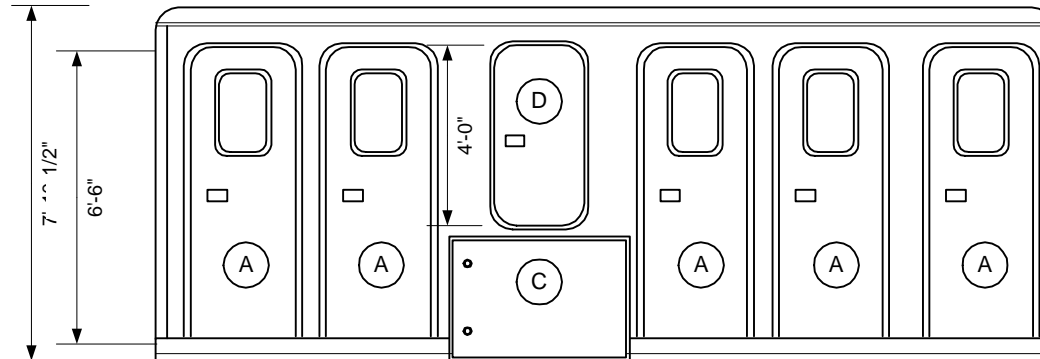

- Lowerters to ground
- 2000 flush capacity
- Container S hipable
- Requires 30amp 110AC
- .040 Aluminum Exterior
- 1.5 GPM metered showers
- Hydraulic Electric Disk Brakes
- 500 gallon waste tank capacity
- 250 gallons fresh water storage
- Uses less than a quart per flush
- 5 Jets Marine Vacumerator Toilets
- Obscure windows in radius doors
- Heat & Air Conditioned 15,000BTU
- 10000 pound retractable suspension
- 17.5 x 6.75 16 ply 6000# Radial Tires
- All metal and composite construction
- LED 50,000 hour burn lighting and trailer lighting
- Liquefies all waste paper and hygienic products
- Automatic Electric Leveling Jacks 16,000 lb. max
- Rani heated water on de mand propane water heater
- Self Pumping to Sewer Tap up to 100 feet w/10' head 1" line

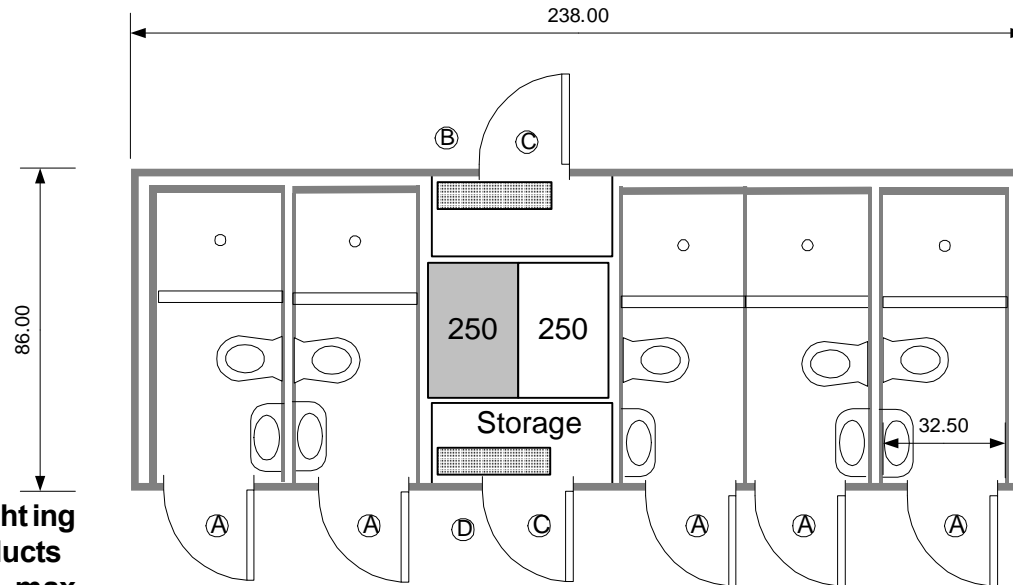

This document is the property of and contains unpublished proprietary information and trade secrets of A.M.S. Global Inc. By accepting possession of the document the recipient agrees to make no copies transcriptions or any use of this document or the information contained herein except as authorized by A.M.S. Global Inc. and further agrees to safe keep this document and return in to A.M.S. Global Inc. upon demand.

Approved by _____



36 4 96 59 253

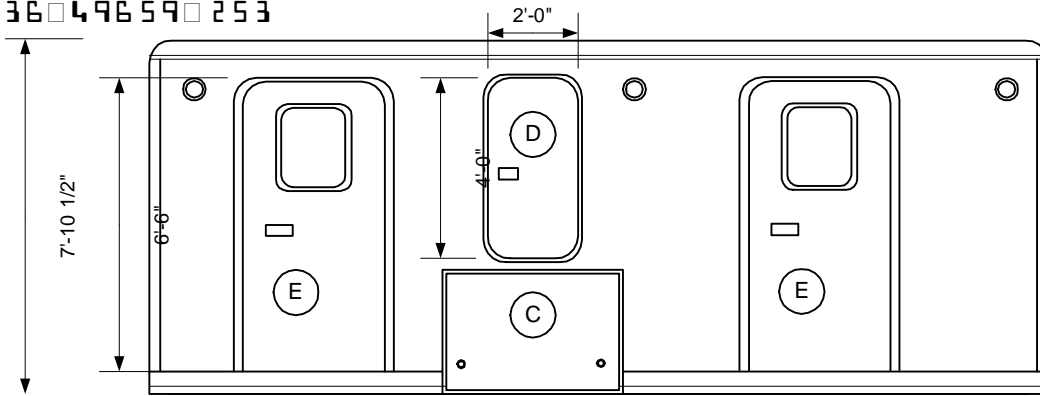

- Ⓐ 78"x24" radius RH
- Ⓑ 48"x24" radius LH
- Ⓒ 32"x49" top hinge
- Ⓓ 48"x24" radius RH
- Ⓔ 78"x38" radius RH
- Ⓕ 78"x24" radius LH
- Ⓖ 77.5"x35.5" radius LH
- Ⓗ 22.5"Hx24"W
- Ⓖ 48"Hx60"W top hinge



Omega 20 ADA 2STS

- 2000 flush capacity
- Lowers to ground
- Container Shipable
- 1 ADA compliant restroom with shower
- 1 ADA accessible restroom with shower
- Hydraulic Surge Disk Brakes
- 2 Jet s™ Marine Toilets & Vacumarator™
- 250 gallon waste tank capacity
- 250 gallons fresh water storage
- Uses less than a quart per flush
- Heat & Air Conditioned 15,000 btu
- Obscure windows in radius doors 9,900
- 10000 pound retractable suspension
- 17.5 x 6.75 Radial Tires
- All metal and composite wet room construction
- LED 50,000 hour burn lighting and trailer lighting
- Liquefies all waste paper and hygienic products
- Rani Heated water on demand metered showers
- Automatic Electric Leveling Jacks 16,000 lb max
- Self Pumping to Sewer Tap up to 100 yards w/10' head
- 240v 50 amp power requirement & propane heat ed/water
- Aluminum ADA ramps w/Stainless steel railing

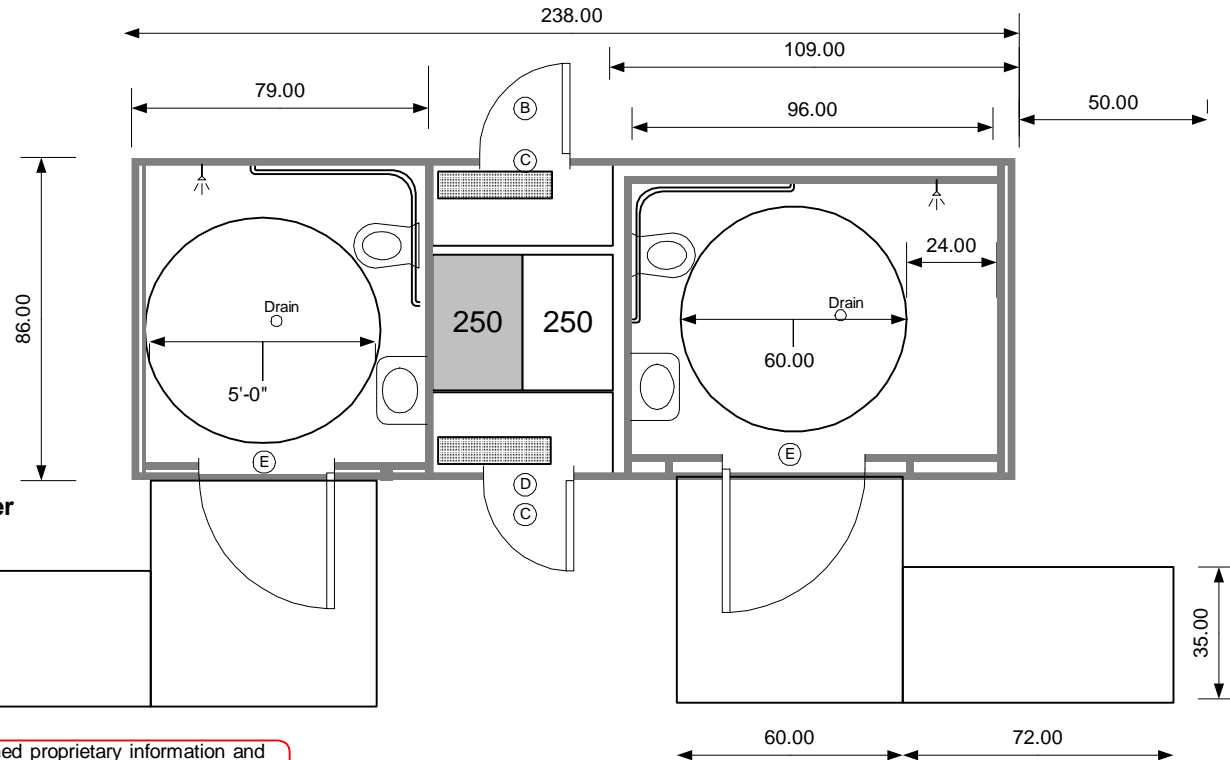

This document is the property of and contains unpublished proprietary information and trade secrets of A.M.S. Global Inc. By accepting possession of the document the recipient agrees to make no copies transcriptions or any use of this document or the information contained herein except as authorized by A.M.S. Global Inc. and further agrees to safe keep this document and return in to A.M.S. Global Inc. upon demand.

Approved by _____



3 2 3 6 9 6 6 8 2 1



Omega 20 ADA 3STS

Openings

- (A) 80"x24" radius RH
- (B) 48"x24" radius LH
- (C) 32"x49" top hinge
- (D) 48"x24" radius RH
- (E) 82"x36" radius RH
- (F) 80"x24" radius LH
- (G) 77.5"x35.5" radius LH

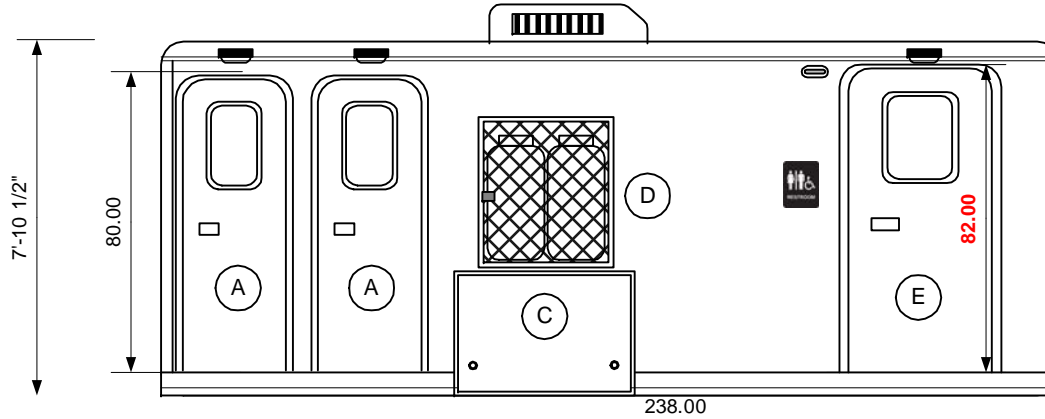

- ADA compliant to 2010 ADA Guidelines**
- Lowlers to ground & Container Shipable
 - 2" camlock to 2" PVC hardpipe sewage adaptor
 - Retractable trailer tongue
 - Porcelain wall hung fixtures
 - 3 On Demand metered shower valves
 - Bobrick fold down shower seat B-5181
 - Stainless Steel Towel, tissue and soap dispensers
 - Gel type battery & Granitised steel flooring
 - Rotationally molded vertical tanks
 - Electric over hydraulic Surge Disk Brakes
 - 3 Jets Marine Toilets & Optima VOD Vacuumator
 - 250 gallon waste tank capacity
 - 250 gallons fresh water storage
 - Uses less than a quart per flush
 - Heat & Air Conditioned 15,000btu / 5,500 btu heat
 - Ducted ventilation & furrion marine power inlet
 - Obscure skylights in radius doors
 - 10,000 pound retractable suspension
 - 17.5 x 6.75 16 ply Radial Tires & wet bearings
 - All metal and composite construction
 - LED 50,000 hour burn lighting and trailer lighting
 - Liquefies all waste paper and hygienic products
 - Automatic Electric Leveling Jacks 16,000 lb. max.
 - Self Pumping to Sewer Tap up to 100 yards w/10' head
 - 240v 50 amp power requirement
 - Aluminum ADA ramp w/Stainless steel railing
 - Wheel cover doors and flush door latches
 - 4" curbs are optional on ADA landing
 - Optional 500 gallon waste & no water tank
 - Deviation from this design will be cost plus

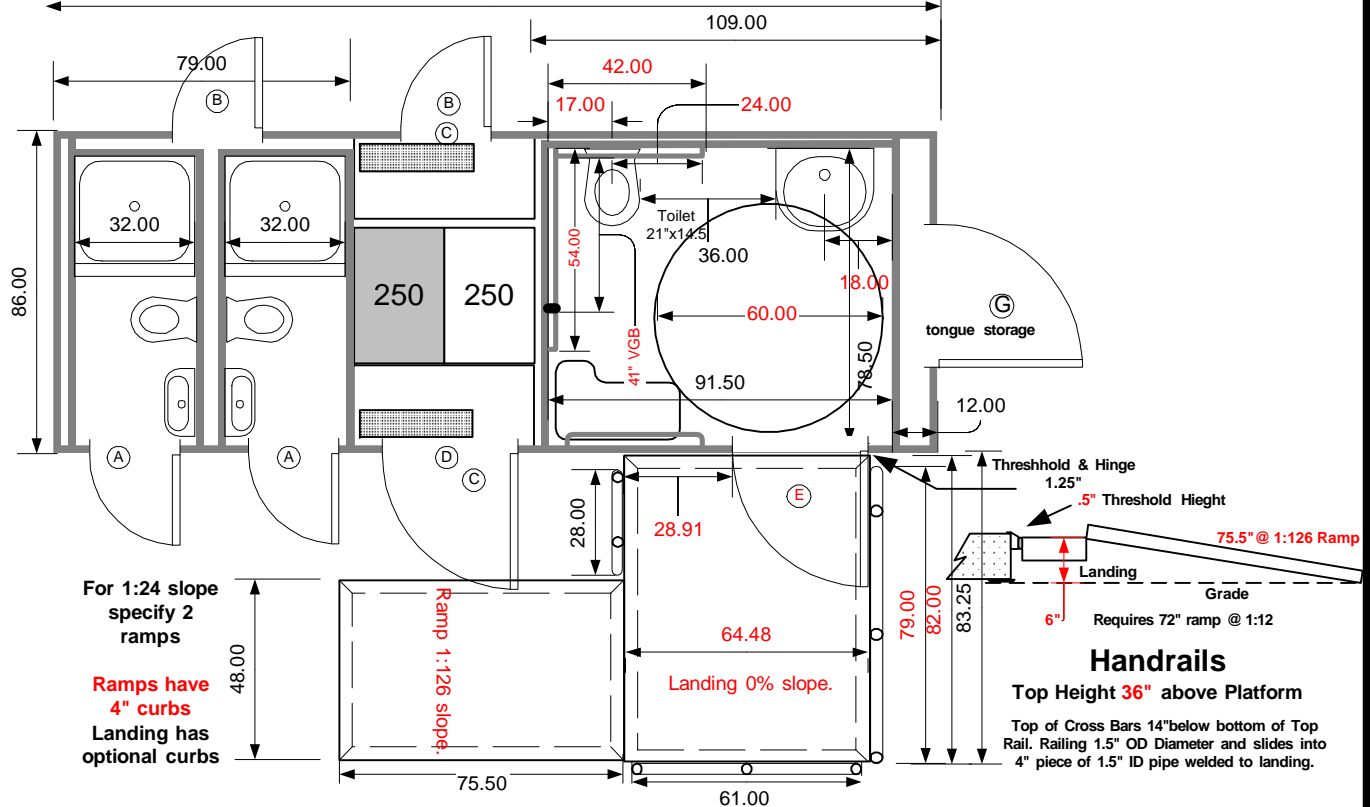

Approved by _____

This document is the property of and contains unpublished proprietary information and trade secrets of A.M.S. Global Inc. By accepting possession of the document the recipient agrees to make no copies transcriptions or any use of this document or the information contained herein except as authorized by A.M.S. Global Inc. and further agrees to safe keep this document and return in to A.M.S. Global Inc. upon demand.

These restrooms are designed to be compliant with all current guidelines as we are aware of . Many guidelines have gray areas and points open to interpretation. Different entities may have differed interpretations or local differences. We suggest getting approvals of final plans from the authorities in the local the unit will be placed



410073640875



Omega 20 3S 2WD

- (A) 78"x24" radius RH
- (B) 48"x24" radius LH
- (C) 32"x49" top hinge
- (D) 48"x24" radius RH
- (E) 78"x36" radius RH
- (F) 78"x24" radius RH
- (G) 77.5"x35.5" radius LH

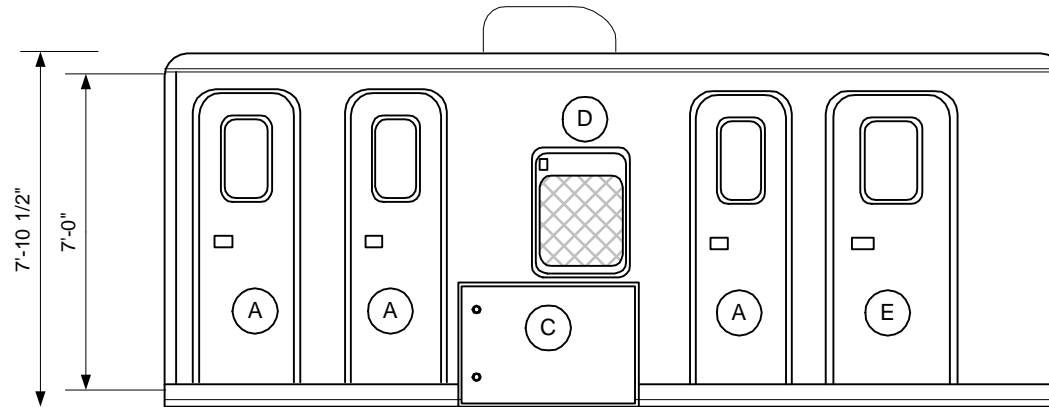

- Container Shipable
- Lowers to ground with retractable tongue
- Rotationally m olded tanks
- Requires 50amp 240AC
- .040 Aluminum Exterior
- 1.5 GPM metered showers
- Hydraulic Electric Disk Brakes
- 500 gallons fresh w ater st orage (100+ showers)
- Obscure windows in radius doors
- Heat & Air Conditioned 15,000BTU
- 10,000 pound retractable suspension
- 17.5 x 6.75 16 ply 6000# Radial Tires
- All metal and com posite constr uction
- LED 50,000 hour bur n light ing and trailer light ing
- Liquefies all w aste paper and most hy gienic products
- Automatic E lectric Leveling Jacks 16,000 lb. max
- Rani heated water on demand propane or electric w ater heater

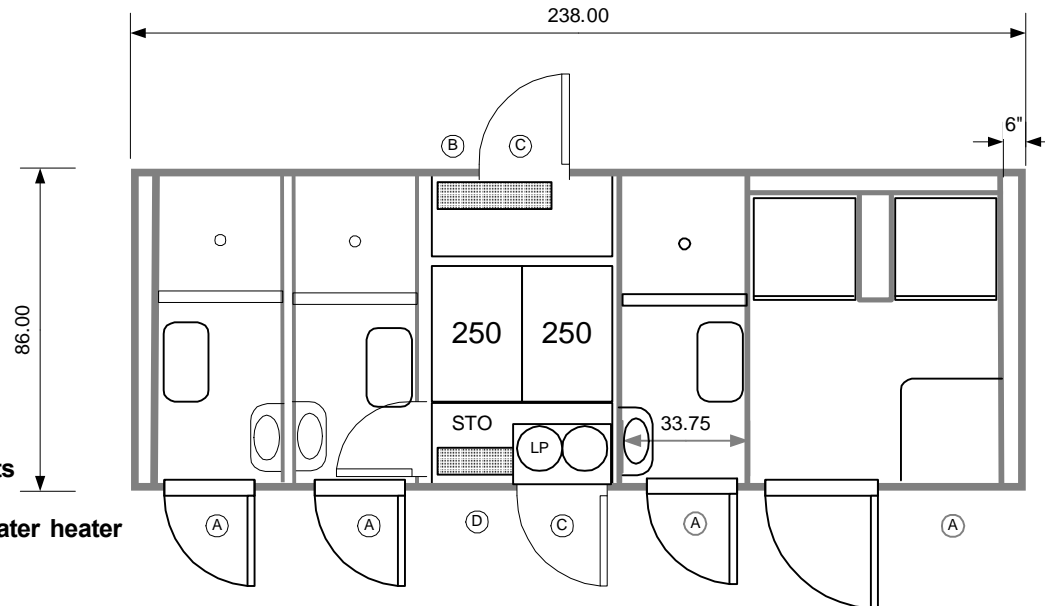

This document is the property of and contains unpublished proprietary information and trade secrets of A.M.S. Global Inc. By accepting possession of the document the recipient agrees to make no copies transcriptions or any use of this document or the information contained herein except as authorized by A.M.S. Global Inc. and further agrees to safe keep this document and return in to A.M.S. Global Inc. upon demand.

Approved by _____



360401590950



- Ⓐ 78"x24" radius RH
- Ⓑ 48"x24" radius LH
- Ⓒ 32"x49" top hinge
- Ⓓ 48"x24" radius RH
- Ⓔ 78"x38" radius RH
- Ⓕ 78"x24" radius LH
- Ⓖ 77.5"x34" radius LH

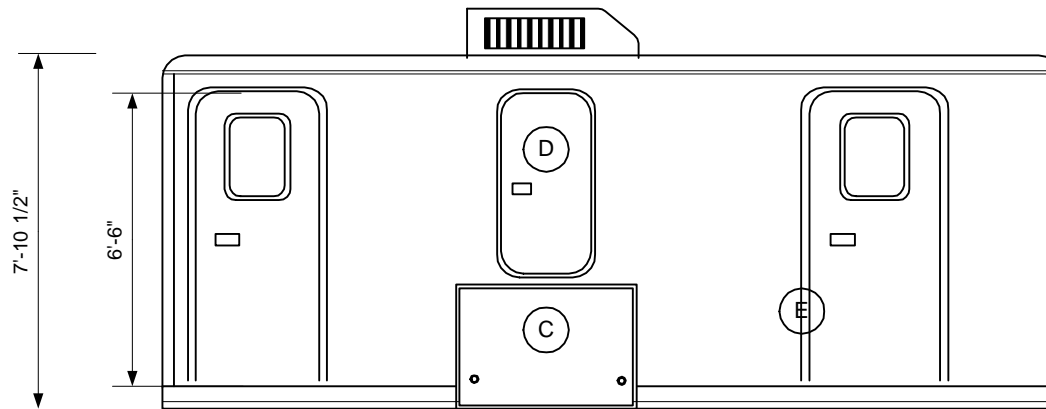

Omega 20 ADA 1ST 2S

This document is the property of and contains unpublished proprietary information and trade secrets of A.M.S. Global Inc. By accepting possession of the document the recipient agrees to make no copies transcriptions or any use of this document or the information contained herein except as authorized by A.M.S. Global Inc. and further agrees to safe keep this document and return in to A.M.S. Global Inc. upon demand.

Approved by _____

- Complies with ADA 2010
- Lowers to ground
- 2000 flush capacity
- Container Shipable
- Requires 50amp 240 VAC
- .040 Aluminum Exterior
- Hydraulic Electric Disk Brakes
- 250 gallon waste tank capacity
- 250 gallons fresh water storage
- Uses less than a quart per flush
- Jets Marine Vacuumator Toilet
- Obscure windows in radius doors
- Heat & Air Conditioned 15,000BTU
- 10000 pound retractable suspension
- 17.5 x 6.75 16 ply 6000# Radial Tires
- 2 Heat On Demand propane metered showers
- All metal and composite construction
- LED 50,000 hour burn lighting and trailer lighting
- Liquefies all waste paper and hygienic products
- Automatic Electric Leveling Jacks 16,000 lb. max
- Self Pumping to Sewer Tap over 100 feet w/10' head 1" line

