

10 380 2 1 8 5 2

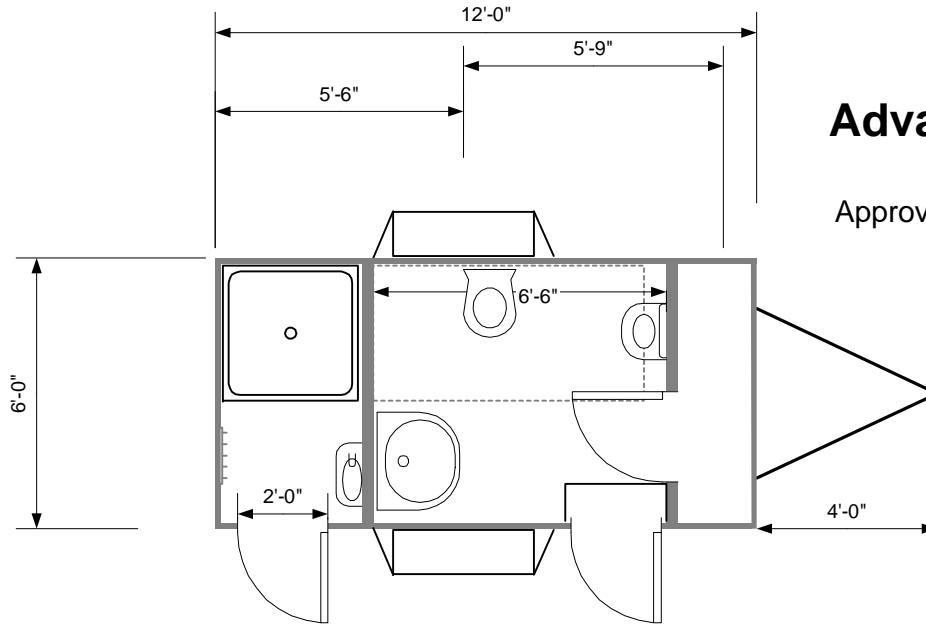

Advanced Performance 12 1STSU

Approved by _____



- Requires 50amp 240AC
- 16,000 BTU A/C 6700 watts heat
- Led Porch Lighting
- 1 Toilet 1 urinal 1 shower 2 sinks
- Electric heat on demand heated water
- Obscure windows in radius doors
- LED 30,000 hour burn lighting and trailer lighting
- 125 Gallon waste tank
- Porcelain wall hung sinks & metered faucets
- Stainless steel towel, tissue & soap dispensers
- Vandalproof shower head and clothes hooks
- 2 Framed shatterproof mirrors
- Diamond plate Double Epoxy Ganitised Steel Floor
- .040 white aluminum exterior
- 1.5" steel studs all metal and composite construction
- Two 1 step landings and trailer levelers
- 2 5/16" Bulldog Coupling and jack

This document is the property of and contains unpublished proprietary information and trade secrets of A.M.S. Global Inc. By accepting possession of the document the recipient agrees to make no copies transcriptions or any use of this document or the information contained herein except as authorized by A.M.S. Global Inc. and further agrees to safe keep this document and return in to A.M.S. Global Inc. upon demand.

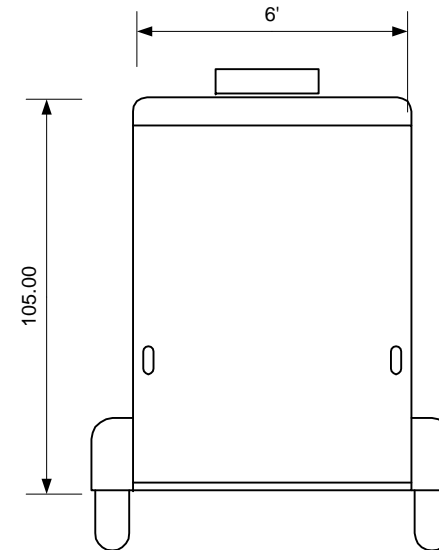
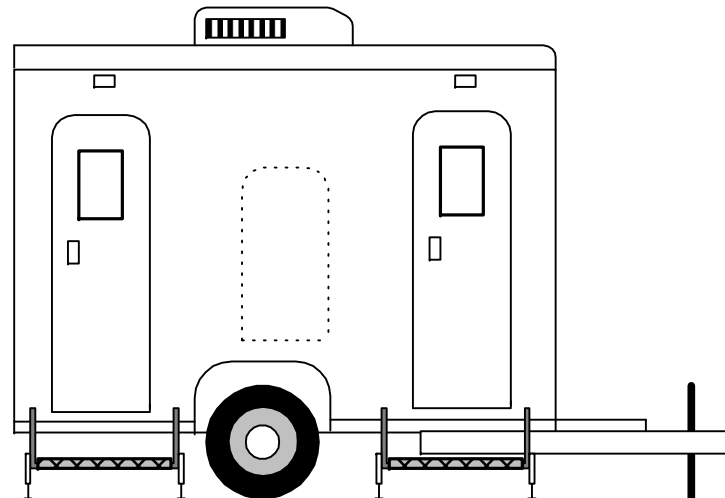

8 3 9 9 1 8 5 2 5



Advanced Performance 12 2 S Direct

Approved by _____

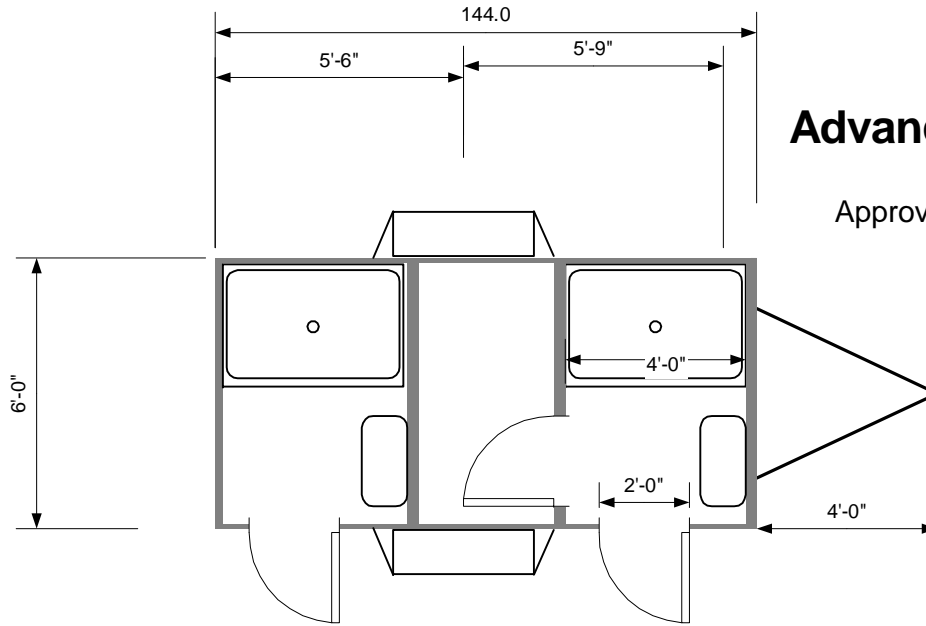

- Requires (2) 30amp 110AC or One 50 amp 240 AC
- Two shower vent fans or 13,500 btu AC with heat
- Led Porch Lighting
- Obscure windows in radius doors
- LED 50,000 hour burn lighting and trailer lighting
- Direct connect to sewer and water
- Metered shower faucets and pressure tank
- 4 hook towel hangers 2 benches
- Fabric shower curtains and rods
- Soap holders and tank less water heaters
- 2 showers with vandal proof heads
- All metal and composite structure
- Walls 1.5" tubular steel
- Diamond plate Double Epoxy Ganitised Steel Floor
- .040 white aluminum exterior not .030
- 2 one step landings and spare tire
- Very close to the ground- less liability

This document is the property of and contains unpublished proprietary information and trade secrets of A.M.S. Global Inc. By accepting possession of the document the recipient agrees to make no copies transcriptions or any use of this document or the information contained herein except as authorized by A.M.S. Global Inc. and further agrees to safe keep this document and return in to A.M.S. Global Inc. upon demand.

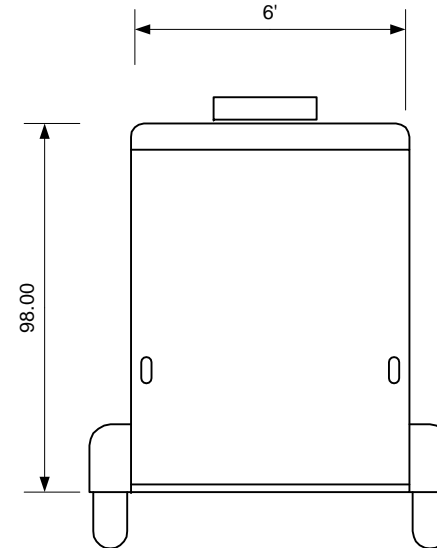
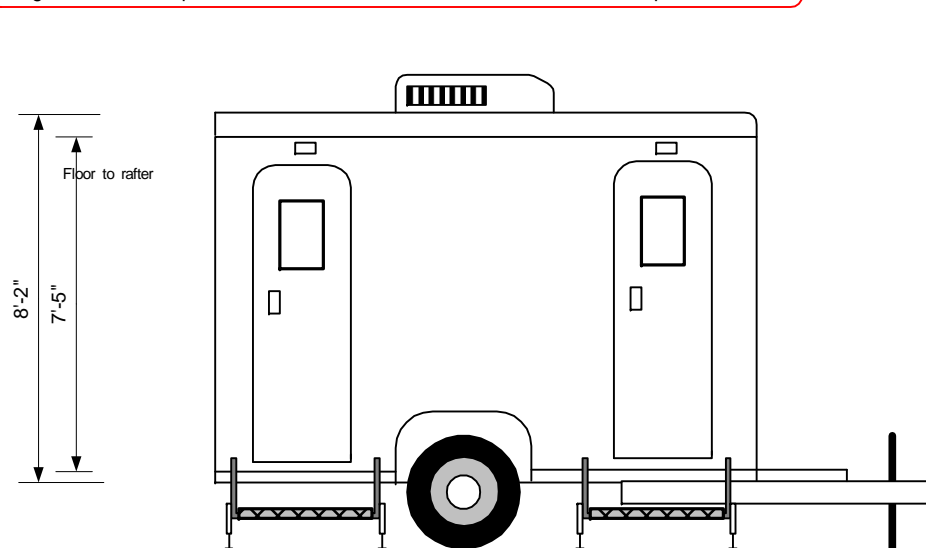

90137190650



Advanced Performance 12 2 S S Dfect

Approved by _____

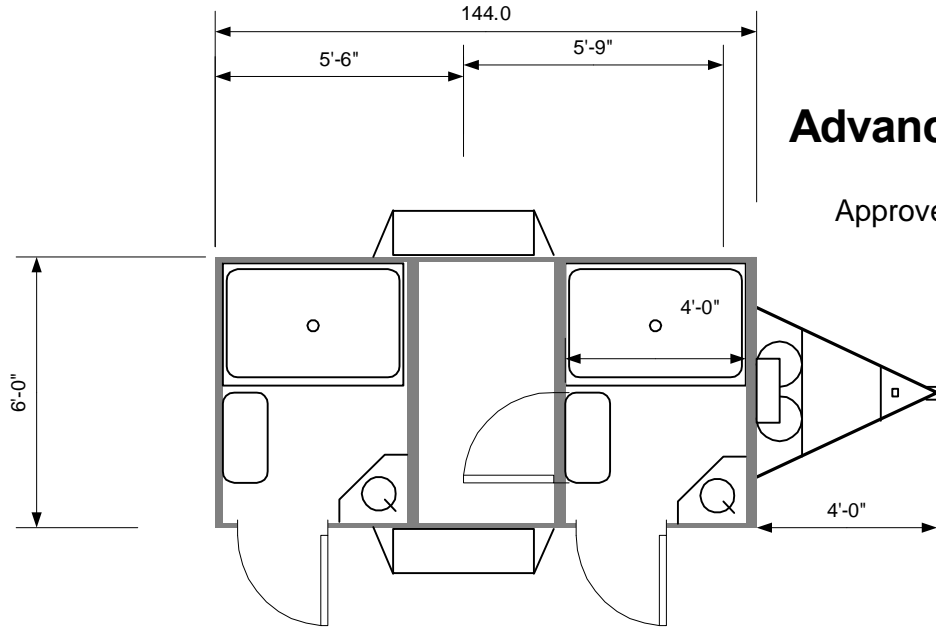

- Requires 30amp 110AC
- 15,000 btu AC with 5500 btu heat
- Led Porch Lighting
- Obscure windows in radius doors
- LED 50,000 hour burn lighting and trailer lighting
- Direct connect to sewer and water
- Metered shower faucets and pressure tank
- 4 hook towel hangers 2 benches
- corner porcelain sinks with hot & cold water
- Fabric shower curtains and rods
- 2 showers with vandal proof heads
- All metal and composite structure
- Walls 1.5" tubular steel
- Heavy Duty dropleg tounge jack
- Diamond plate Double Epoxy Ganitised Steel Floor
- .040 white aluminum exterior not .030
- 2 one step landings and spare tire
- Very close to the ground- less liability

This document is the property of and contains unpublished proprietary information and trade secrets of A.M.S. Global Inc. By accepting possession of the document the recipient agrees to make no copies transcriptions or any use of this document or the information contained herein except as authorized by A.M.S. Global Inc. and further agrees to safe keep this document and return in to A.M.S. Global Inc. upon demand.

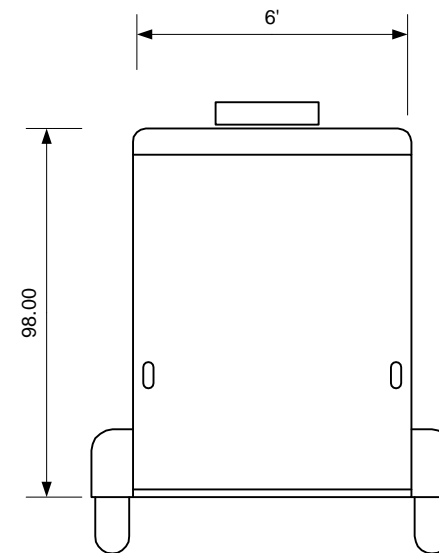
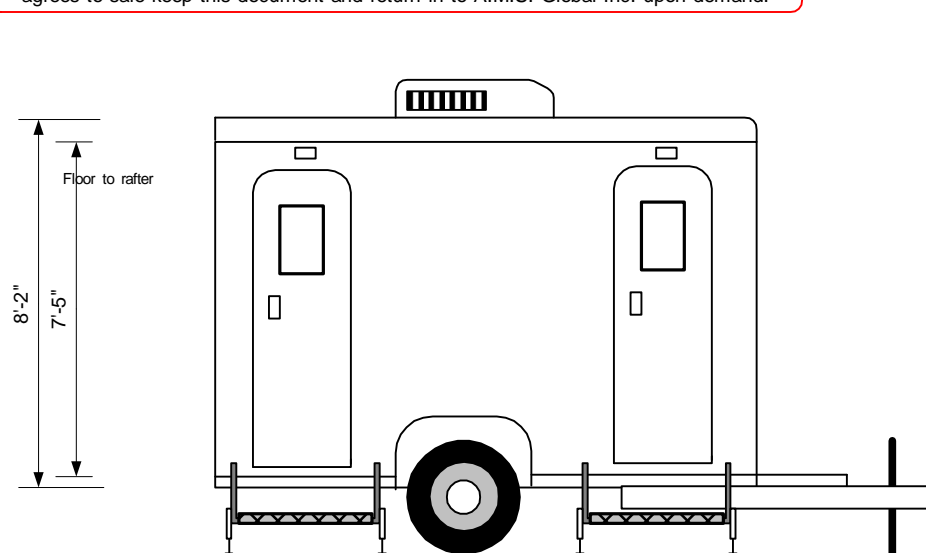

160895290894



Advanced Performance 12 2ST 1S

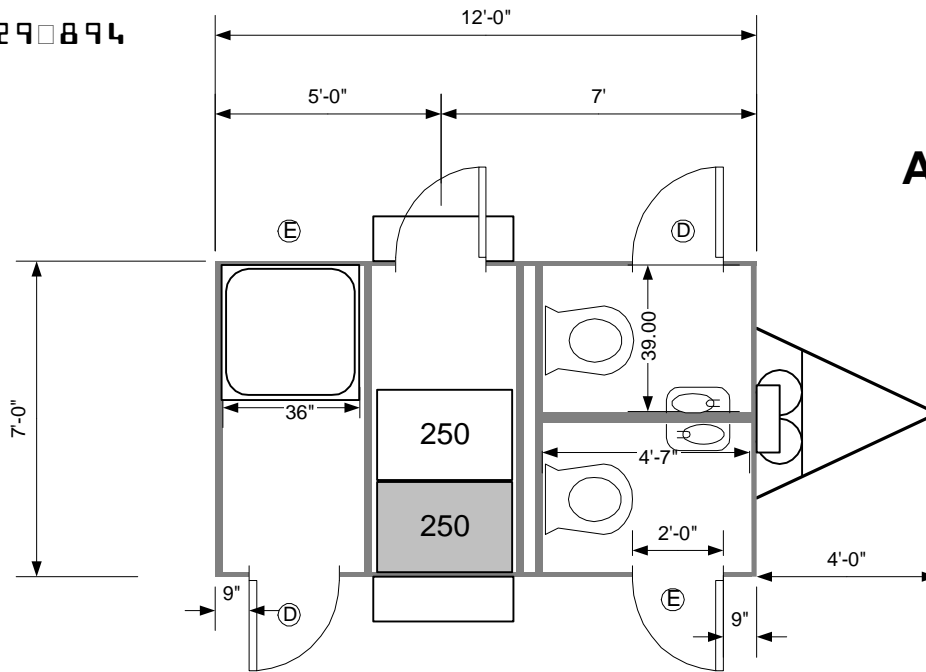

- Requires 20amp 120vac
- 15,000 BTU airconditioner w with heat
- Led Por ch Lighting
- Uses a pint per flush
- 45 AMP power converter
- 2 Jets™ Marine Vacumerator™ Toilets
- Jets™ 10NT Vacumerator™ & Gel Battery
- Obscure w indows in radius doors
- 2 showers with metered shower valves
- LP heat on demand water & 2 40# lp bottles
- 7000 # axle and 3 one step landings
- Heavy Duty dropleg tounge jack
- LED 50,000 hour burn lighting and trailer lighting
- Liquefies all waste and hygienic products
- Self Pumping to Sewer Tap
- Over 100' w/10' head 1" line
- Porcelain wall hung fixtures & metered faucets
- Acrylic unbreakable mirrors
- Diamond plate Double Epoxy Ganitised Steel Floor
- .040 Aluminium Exterior 1.5 inch tubular walls
- All composite walls interior -- No wood

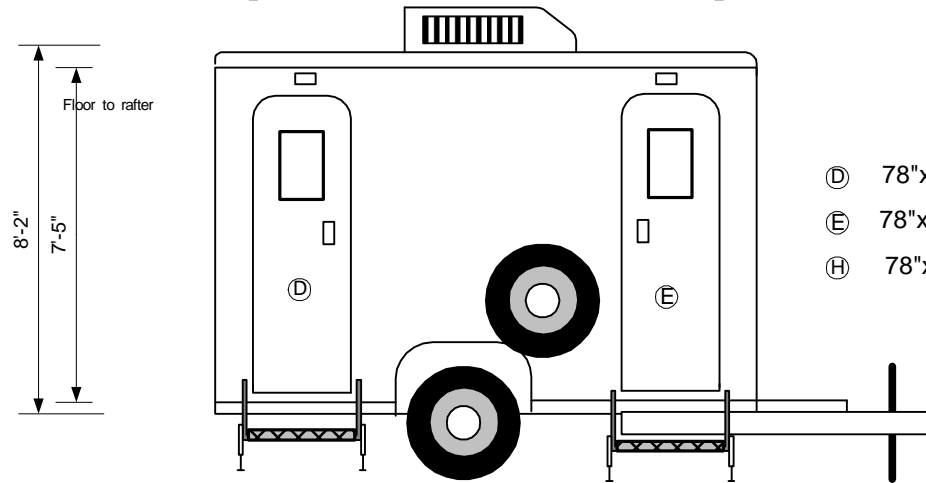

- ⓓ 78"x24" radius LH
- ⓔ 78"x24" radius RH
- ⓗ 78"x24" radius LH interior

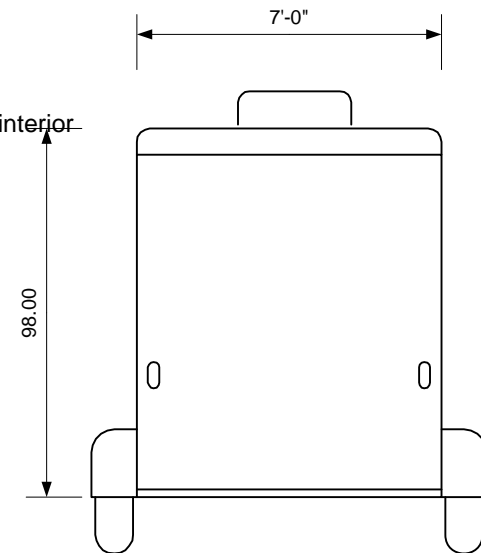

Approved by _____

This document is the property of and contains unpublished proprietary information and trade secrets of A.M.S. Global Inc. By accepting possession of the document the recipient agrees to make no copies transcriptions or any use of this document or the information contained herein except as authorized by A.M.S. Global Inc. and further agrees to safe keep this document and return in to A.M.S. Global Inc. upon demand.



150754290828



Advanced Performance 12 2STS

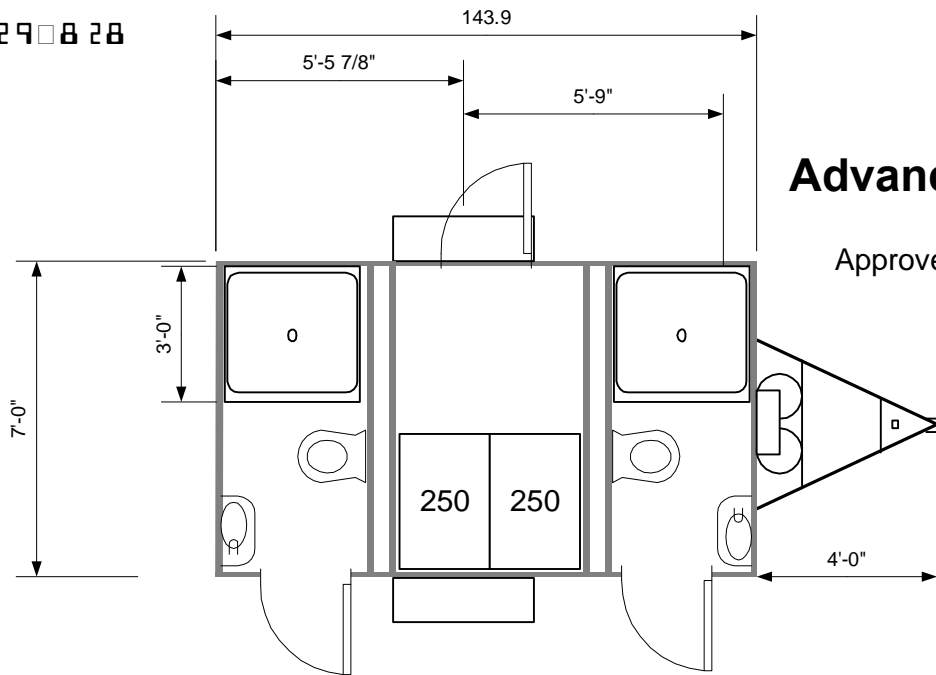

Approved by _____

- Requires 30amp 110AC
- 15,000 btu AC with 5500 BTU heat
- Led Por ch Lighting
- Obscure w indows in radius doors
- LED 50,000 hour burn lighting and trailer lighting
- Jets™ w all hung toilets to sewer and w ater
- Metered shower faucets and pressure tank
- On dem and heated w ater
- 4 ho ok towel hangers 2 benches
- porcelain sinks with hot & cold w ater
- Fabric shower curtains and rods
- 2 showers with vandal proof heads
- All metal and composite st ructure
- Walls 1.5" tubular steel
- Heavy Duty dropleg tounge jack
- Diamond plate Double Epoxy Ganitised Steel Floor
- .040 white aluminum exterior not .030
- 2 one step landings and spare tire
- Very close to the ground- less liability

This document is the property of and contains unpublished proprietary information and trade secrets of A.M.S. Global Inc. By accepting possession of the document the recipient agrees to make no copies transcriptions or any use of this document or the information contained herein except as authorized by A.M.S. Global Inc. and further agrees to safe keep this document and return in to A.M.S. Global Inc. upon demand.

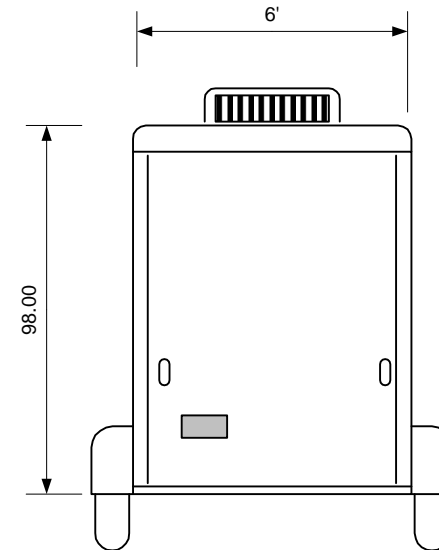
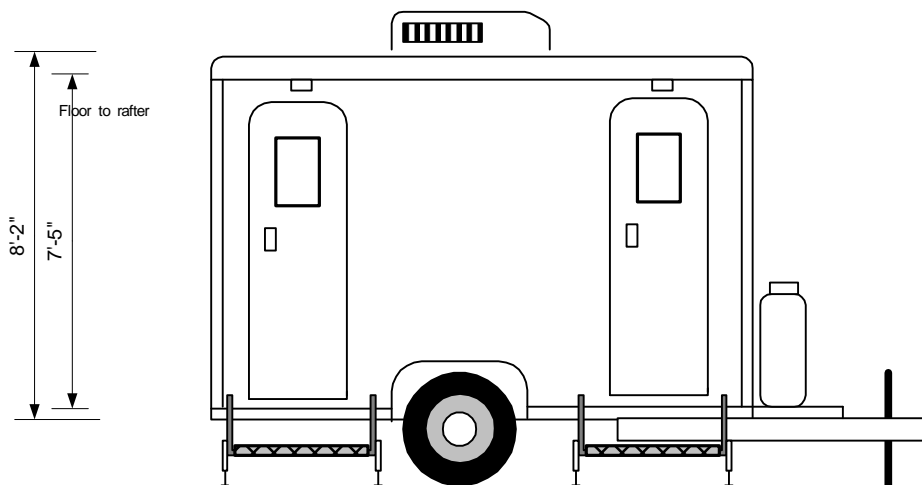

1 1 2 3 0 2 3 0 3 0 9



Advanced Performance 12 2STS Direct

Approved by _____

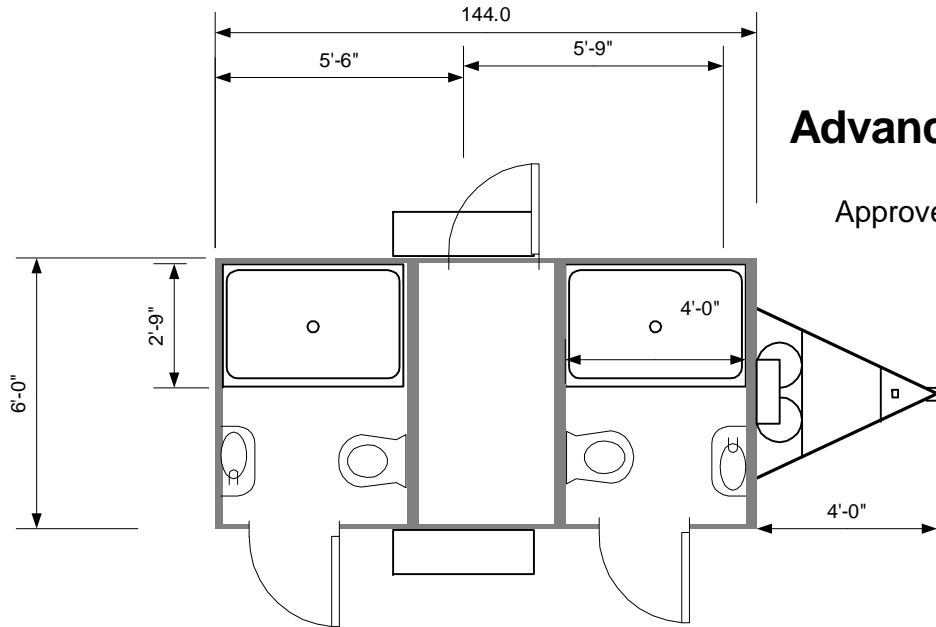

- Requires 30amp 110AC
- 15,000 btu AC with 5500 BTU heat
- Led Porch Lighting
- Obscure windows in radius doors
- LED 50,000 hour burn lighting and trailer lighting
- Direct connect wall hung toilets to sewer and water
- Metered shower faucets and pressure tank
- 4 hook towel hangers 2 benches
- porcelain sinks with hot & cold water
- Fabric shower curtains and rods
- 2 showers with vandal proof heads
- All metal and composite structure
- Walls 1.5" tubular steel
- Heavy Duty dropleg tounge jack
- Diamond plate Double Epoxy Ganitised Steel Floor
- .040 white aluminum exterior not .030
- 2 one step landings and spare tire
- Very close to the ground- less liability

This document is the property of and contains unpublished proprietary information and trade secrets of A.M.S. Global Inc. By accepting possession of the document the recipient agrees to make no copies transcriptions or any use of this document or the information contained herein except as authorized by A.M.S. Global Inc. and further agrees to safe keep this document and return in to A.M.S. Global Inc. upon demand.

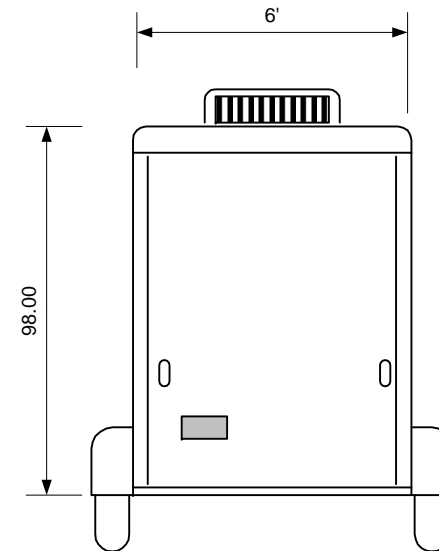
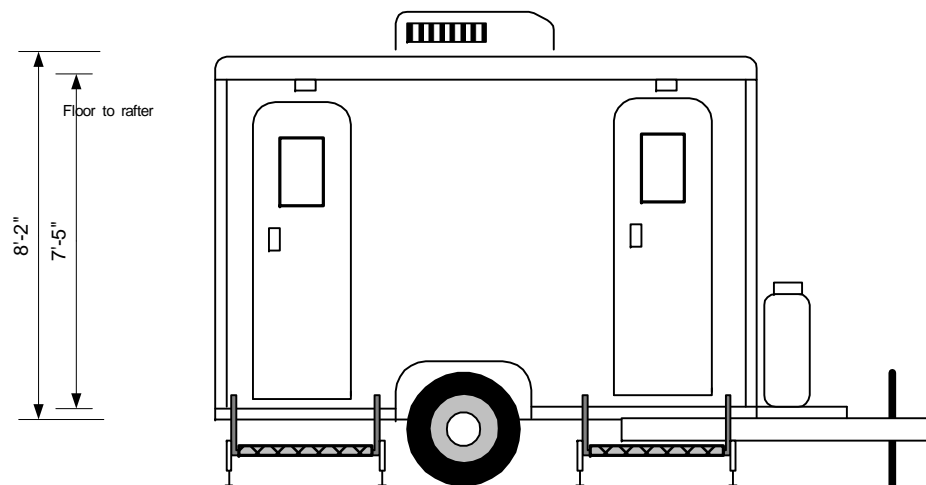

1 2 5 2 1 2 7 5 0 2



Advanced Performance 16-ADA 2STS Direct

- ADA compliant restroom and shower less landing
- Requires 30amp 110AC
- 4 Leveling Jacks
- Steel frame and .040 aluminium exterior
- All metal and composite construction
- 2 gravity toilets 2 showers
- Obscure window in radius door
- Heat 5,500 watt & Air Conditioned 15,000BTU
- LED 50,000 hour burn lighting and trailer lighting
- All porcelain wall hung sinks
- 3000 # axle & removable tongue
- Heat on demand propane showers
- 2 1500 watt heaters

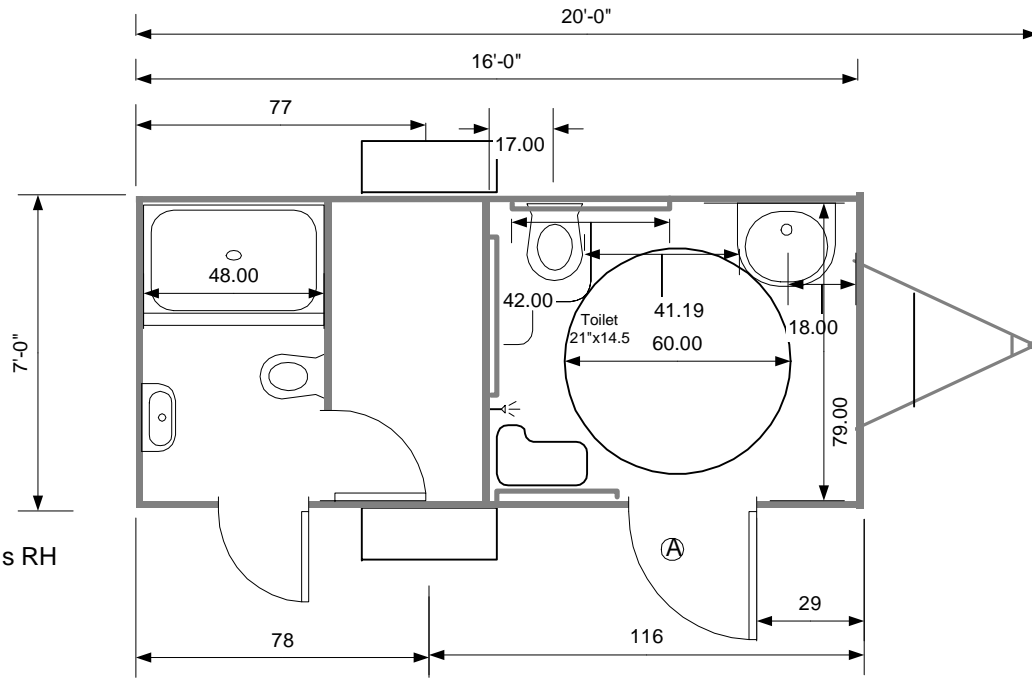

Ⓐ 78"x36" radius RH

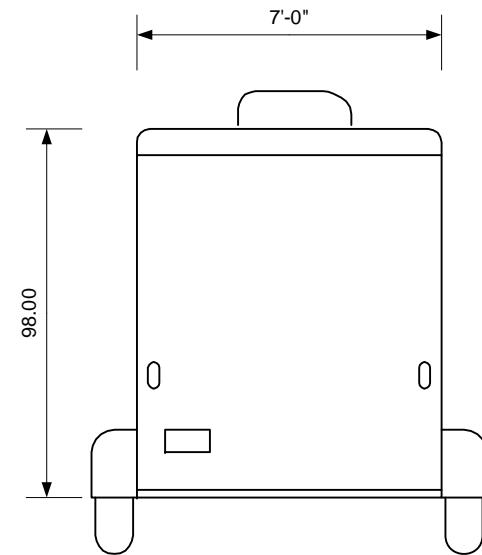
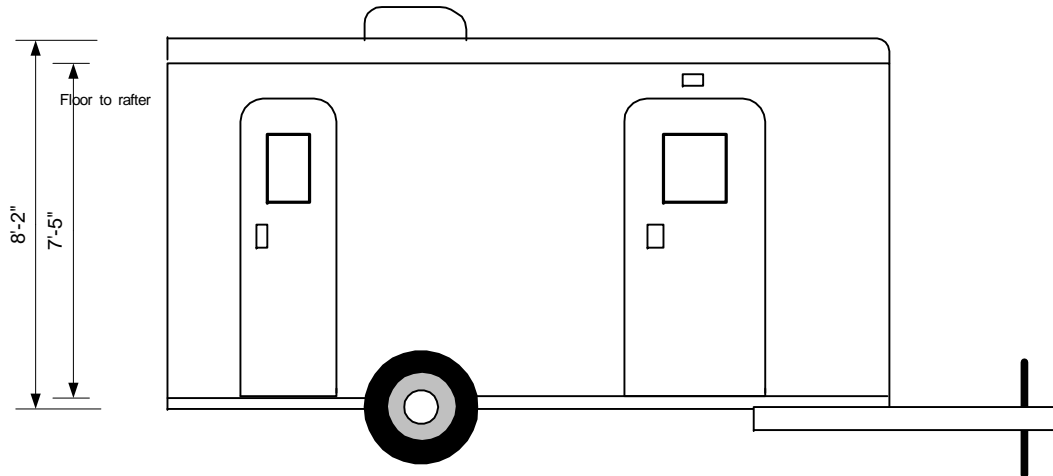

This document is the property of and contains unpublished proprietary information and trade secrets of A.M.S. Global Inc. By accepting possession of the document the recipient agrees to make no copies transcriptions or any use of this document or the information contained herein except as authorized by A.M.S. Global Inc. and further agrees to safe keep this document and return in to A.M.S. Global Inc. upon demand.

Approved by _____



19 17335 817

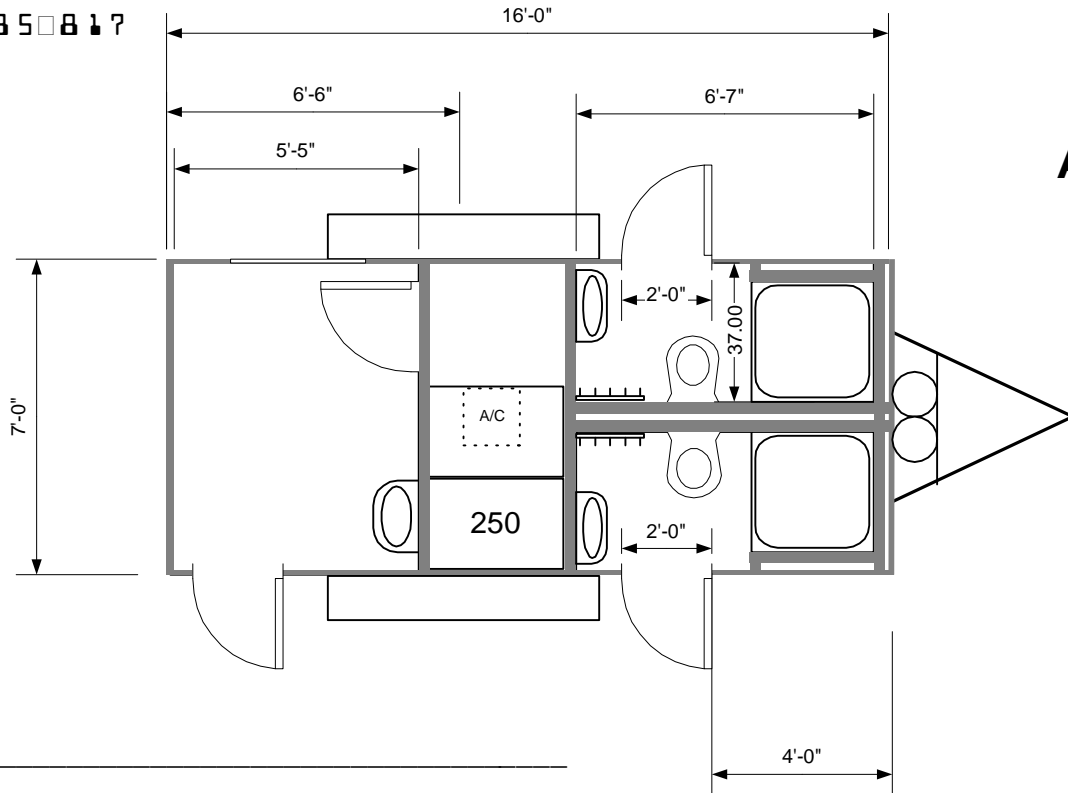

Advanced Performance APF16-STS

- 2000 flush capacity
- Requires 30amp 110AC
- Steel frame and exterior
- 250 gallon waste tank capacity
- 250 gallons fresh water storage 30+ showers
- Uses less than a pint per flush
- 2 Jets™ Marine Toilets & Vacuator™
- Obscure windows in radius doors
- Heat & Air Conditioned 15,000BTU
- LED 50,000 hour burn lighting and trailer lighting
- Liquefies all waste paper and hygienic products
- Self Pumping to Sewer Tap or internal tank
- Up to 100 yards w/10' head 1" line
- Propane heat on demand showers
- Vandal proof shower fixtures 1.5 GPM metered
- Two 40# propane cylinders
- Porcelain wall hung fixtures & metered faucets
- SS Towel, tissue & soap dispensers
- Diamond plate Epoxy G Sanitised Steel Floor

Approved by _____

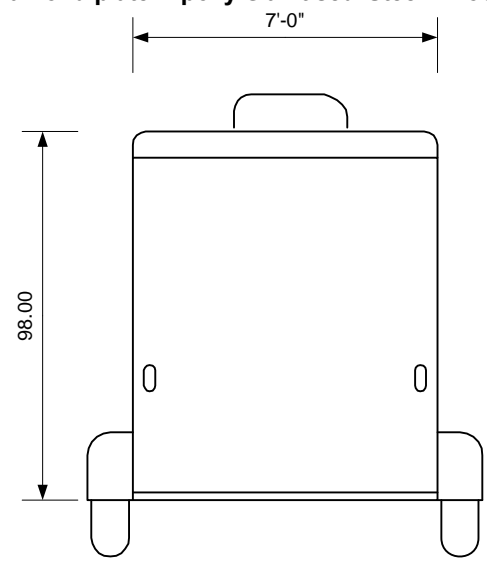
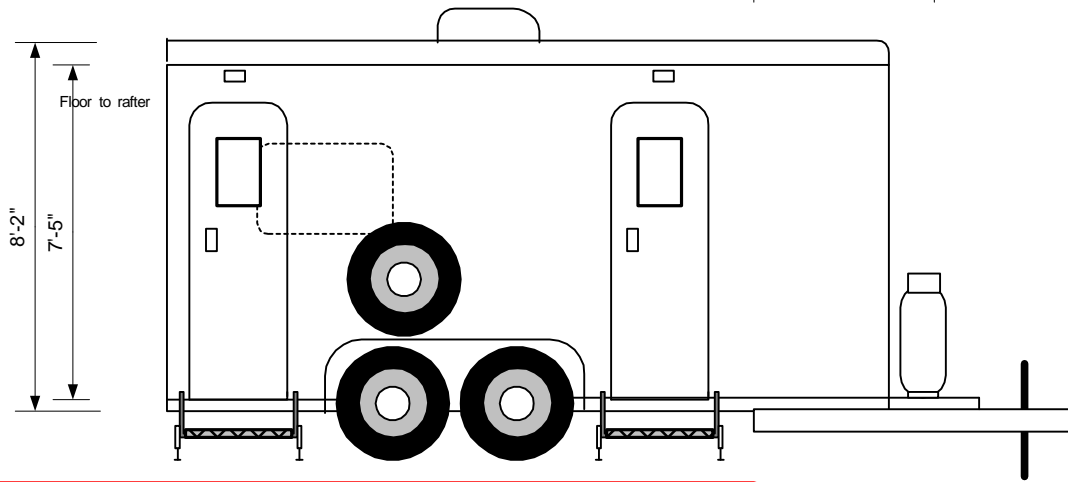

This document is the property of and contains unpublished proprietary information and trade secrets of A.M.S. Global Inc. By accepting possession of the document the recipient agrees to make no copies transcriptions or any use of this document or the information contained herein except as authorized by A.M.S. Global Inc. and further agrees to safe keep this document and return in to A.M.S. Global Inc. upon demand.



150730260813

Advanced Performance 16 4S 4S

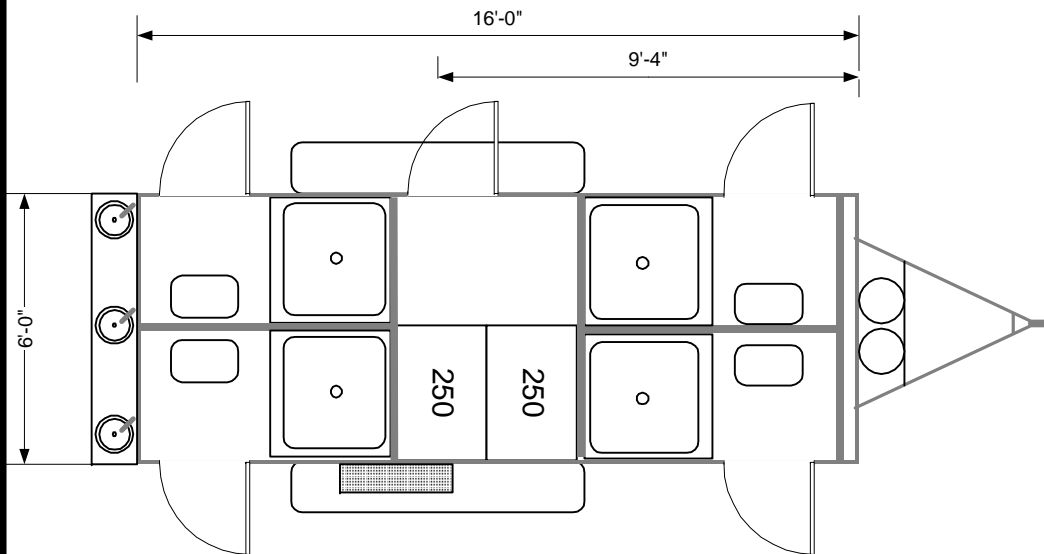

- 500 gallons fresh water storage
- Requires 30amp 120AC
- Steel frame, floor and exterior and all composite wall panels
- Vandal Proof shower heads
- Propane heated on demand water
- 4 private showers with benches
- Vacant Occupied indicating deadbolts
- Propane heat on demand hot water and two 40# bottles
- Leveling jacks, fold up steps & Spare
- Obscure windows in radius doors with Automatic door closers
- 15,000 BTU A/C and 5500 watts heat
- LED 50,000 hour burn lighting and trailer lighting
- Dual axles with Radials and electric brakes
- Three rear sinks at counter height

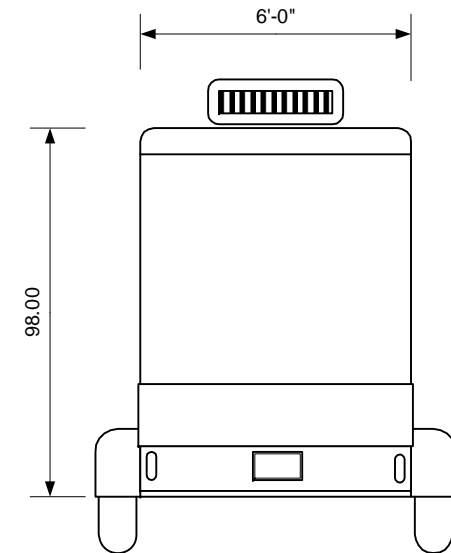
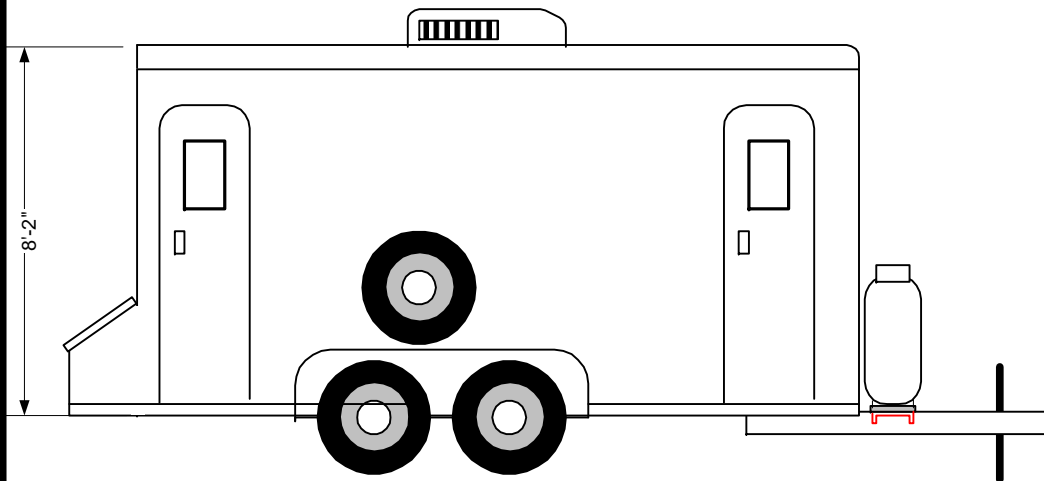

This document is the property of and contains unpublished proprietary information and trade secrets of A.M.S. Global Inc. By accepting possession of the document the recipient agrees to make no copies transcriptions or any use of this document or the information contained herein except as authorized by A.M.S. Global Inc. and further agrees to safe keep this document and return in to A.M.S. Global Inc. upon demand.

Approved by _____



150730260813

Advanced Performance 16 4S 4S

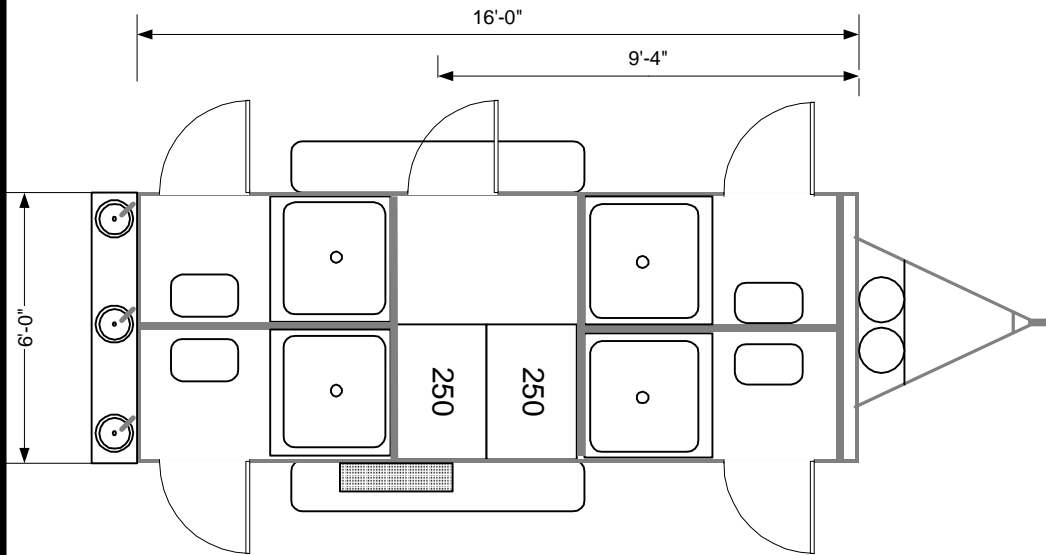

- 500 gallons fresh water storage
- Requires 30amp 120AC
- Steel frame, floor and exterior and all composite wall panels
- Vandal Proof shower heads
- Propane heated on demand water
- 4 private showers with benches
- Vacant Occupied indicating deadbolts
- Propane heat on demand hot water and two 40# bottles
- Leveling jacks, fold up steps & Spare
- Obscure windows in radius doors with Automatic door closers
- 15,000 BTU A/C and 5500 btu heat
- LED 50,000 hour burn lighting and trailer lighting
- Dual axles with Radials and electric brakes
- Three rear sinks at counter height

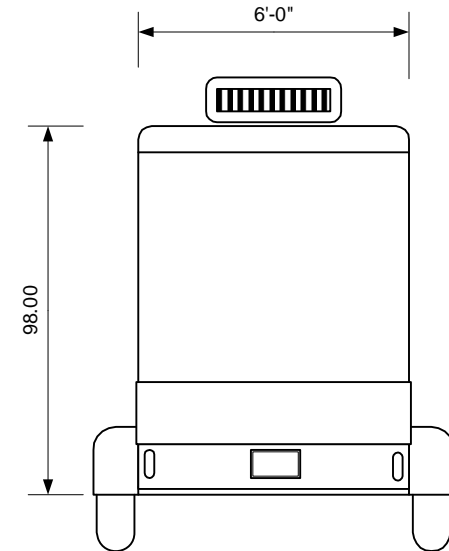
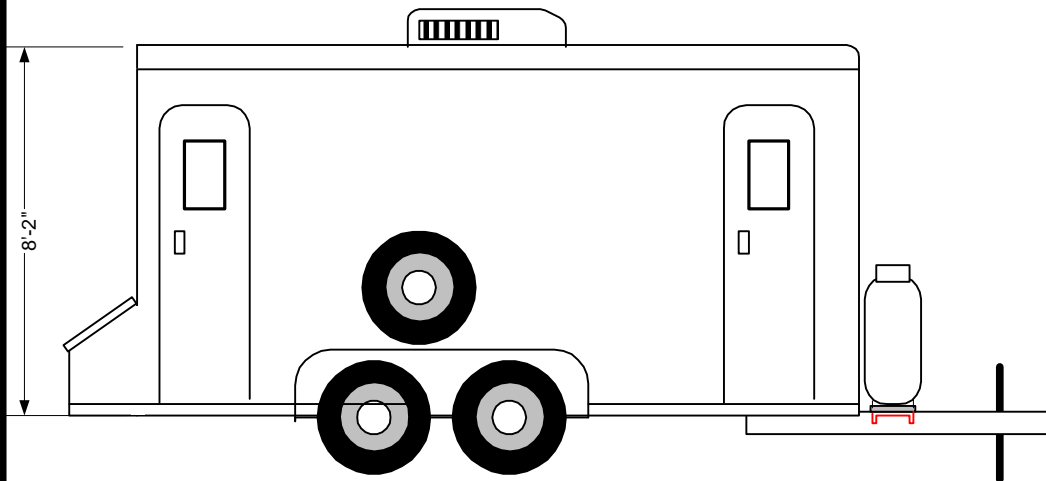

This document is the property of and contains unpublished proprietary information and trade secrets of A.M.S. Global Inc. By accepting possession of the document the recipient agrees to make no copies transcriptions or any use of this document or the information contained herein except as authorized by A.M.S. Global Inc. and further agrees to safe keep this document and return in to A.M.S. Global Inc. upon demand.

Approved by _____



↓ 5 □ 7 30 26 □ 8 ↓ 3

Advanced Performance APF 16 4STS

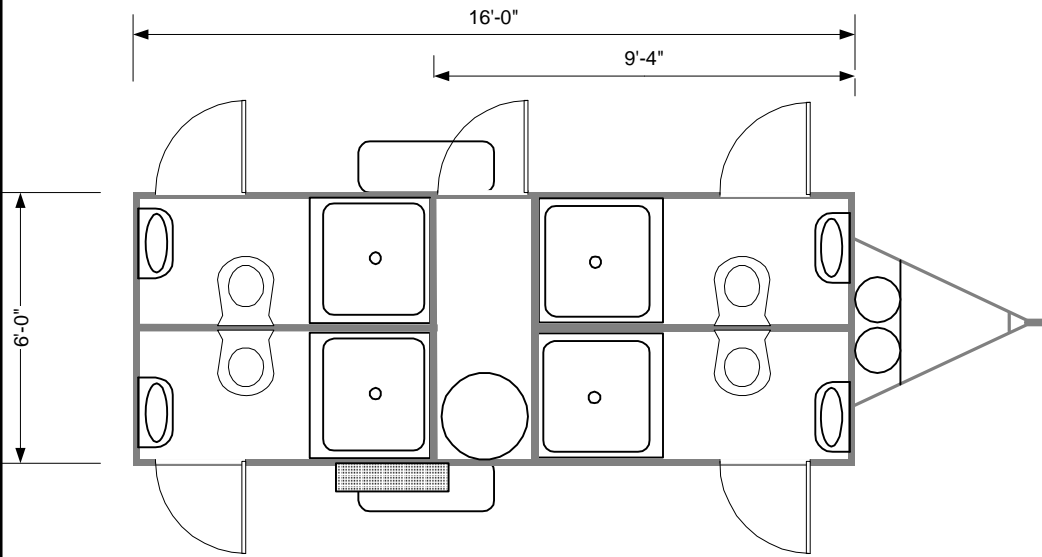

- Requires 30amp 120AC Direct Connect
- Steel frame, floor and exterior and all composite wall panels
- Vandal Proof shower heads
- Propane heated water 50 gallons
- 4 private showers & sinks hot and cold water
- Vacant Occupied indicating deadbolts
- Propane heated water and two 40# bottles
- Leveling jacks, fold up steps & Spare
- Obscure windows in radius doors with Automatic door closers
- 15,000 BTU A/C and 5500 btu heat
- LED 50,000 hour burn lighting and trailer lighting
- Radials and electric brakes

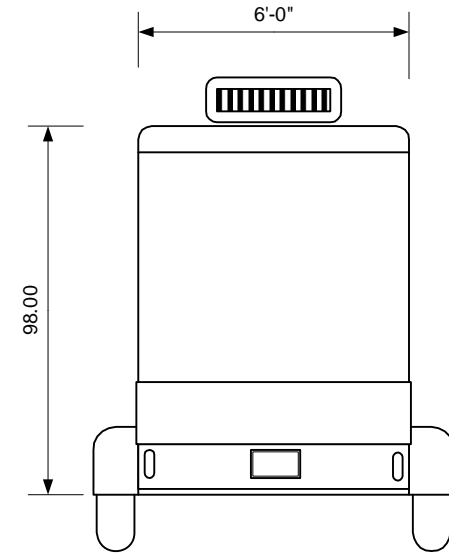
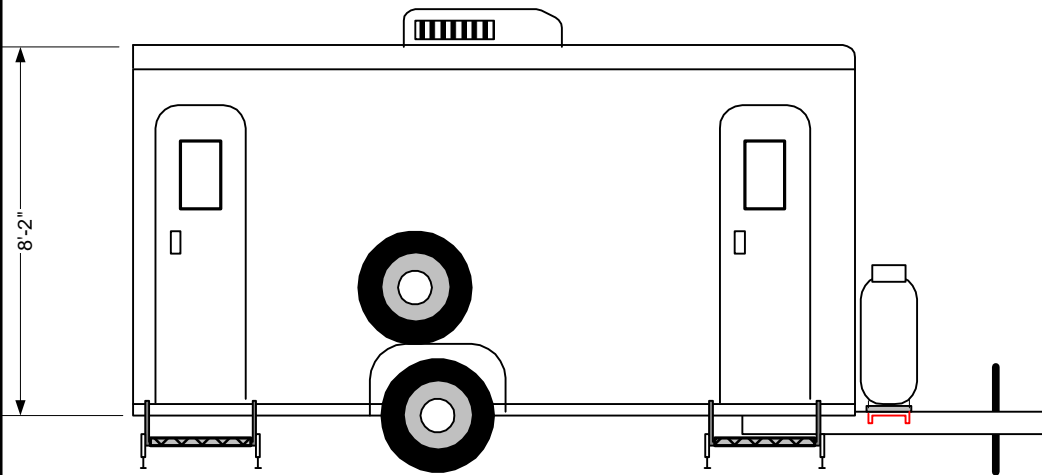

This document is the property of and contains unpublished proprietary information and trade secrets of A.M.S. Global Inc. By accepting possession of the document the recipient agrees to make no copies transcriptions or any use of this document or the information contained herein except as authorized by A.M.S. Global Inc. and further agrees to safe keep this document and return it to A.M.S. Global Inc. upon demand.

Approved by _____



23 5 28 4 4 0 8 6

Advanced Performance APF 18 3SS3WD

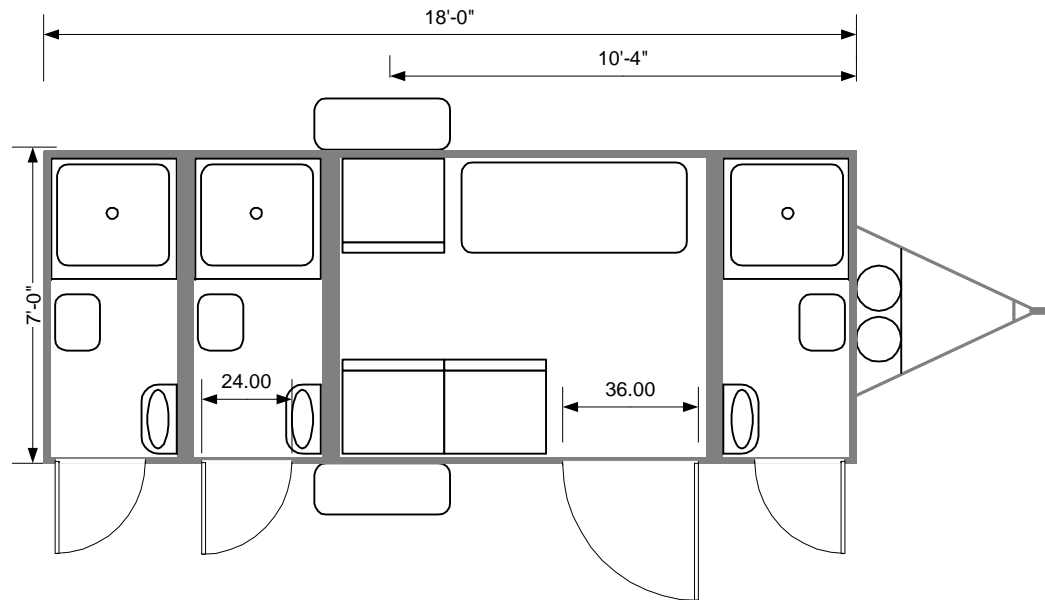

- Requires 30amp 120AC
- Steel frame, floor and all composite wall panels
- .040 Alum. exterior
- 3 stacked washers and driers
- Vandal Proof shower heads
- Propane heated water 50 gallons
- 4 private showers, toilets & sinks hot and cold water
- Vacant Occupied indicating deadbolts
- Propane heated water and two 40# bottles
- Leveling jacks, fold up steps
- Obscure windows in radius doors with Automatic door closers
- 15,000 BTU A/C and 5500 BTU heat
- LED 50,000 hour burn lighting and trailer lighting
- Radials and electric brakes

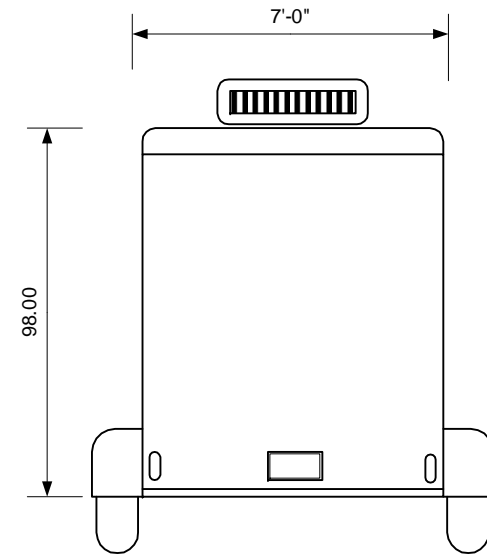
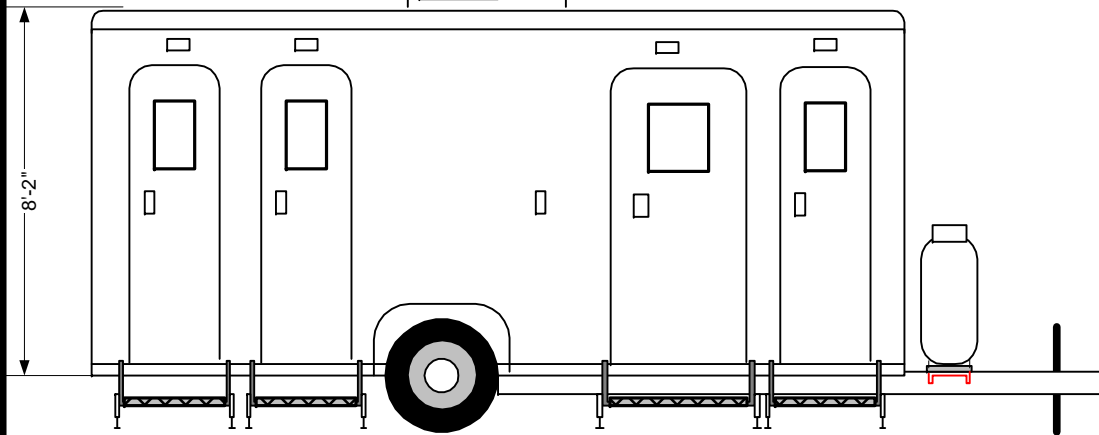

This document is the property of and contains unpublished proprietary information and trade secrets of A.M.S. Global Inc. By accepting possession of the document the recipient agrees to make no copies transcriptions or any use of this document or the information contained herein except as authorized by A.M.S. Global Inc. and further agrees to safe keep this document and return in to A.M.S. Global Inc. upon demand.

Approved by _____



17052837086

Advanced Performance APF 18 4STS

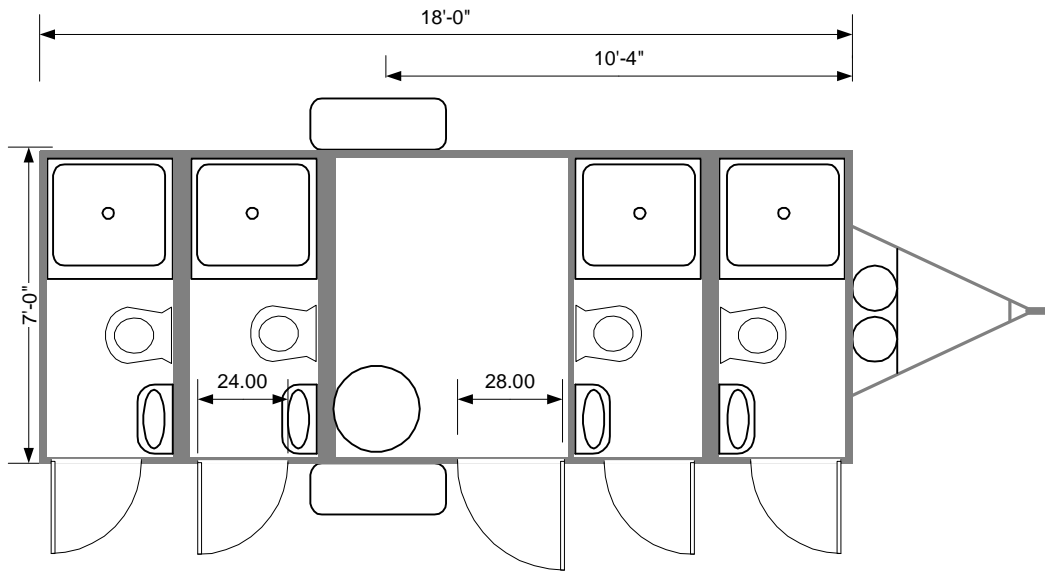

- Requires 30amp 120AC Direct Connect
- Steel frame, floor and exterior and all composite wall panels
- Vandal Proof shower heads
- Propane heated water 50 gallons
- 4 private showers, toilets & sinks hot and cold water
- Vacant Occupied indicating deadbolts
- Propane heated water and two 40# bottles
- Leveling jacks, fold up steps
- Obscure windows in radius doors with Automatic door closers
- 15,000 BTU A/C and 5500 btu heat
- LED 50,000 hour burn lighting and trailer lighting
- Radials and electric brakes

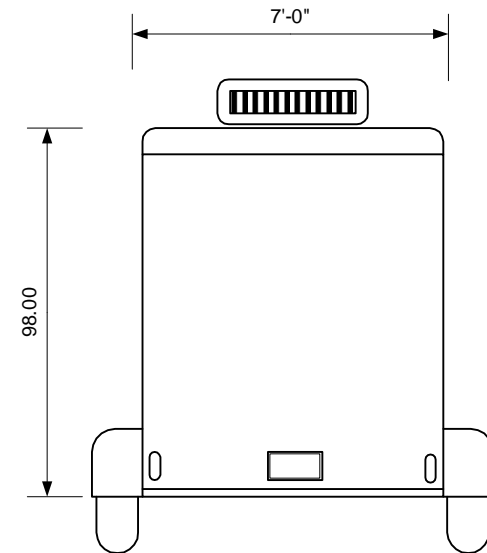
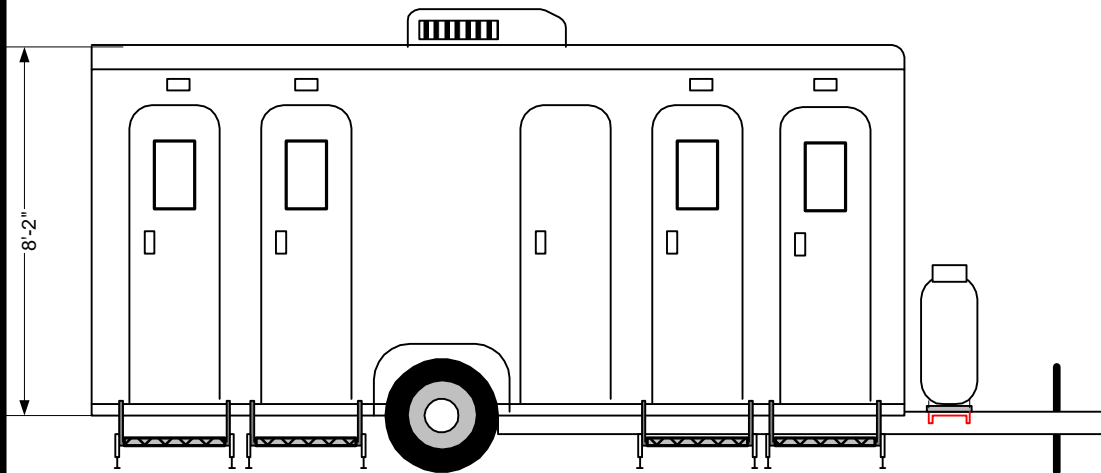

This document is the property of and contains unpublished proprietary information and trade secrets of A.M.S. Global Inc. By accepting possession of the document the recipient agrees to make no copies transcriptions or any use of this document or the information contained herein except as authorized by A.M.S. Global Inc. and further agrees to safe keep this document and return in to A.M.S. Global Inc. upon demand.

Approved by _____



1 7 0 6 6 9 3 8 0 9 8 9

Advanced Performance 18 4S SWD



- Direct Connect
- Stacked washer drier
- Requires 50amp 240VAC
- Vandal Proof shower heads
- All Stainless steel dispensers
- Propane on demand heated water
- 4 private showers benches & sinks
- Vacant Occupied indicating deadbolts
- metal frame, floor, exterior & all composite wall panels
- Propane demand heated water and 4 40# bottles
- Leveling jacks, fold up steps automatic door closers
- Obscure windows in radius doors with Automatic door closers
- 15,000 BTU A/C and 5500 btu central heat
- 5 - 1500 watt bathroom heaters
- LED 50,000 hour burn lighting and trailer lighting
- 16 Radials and electric brakes & spare

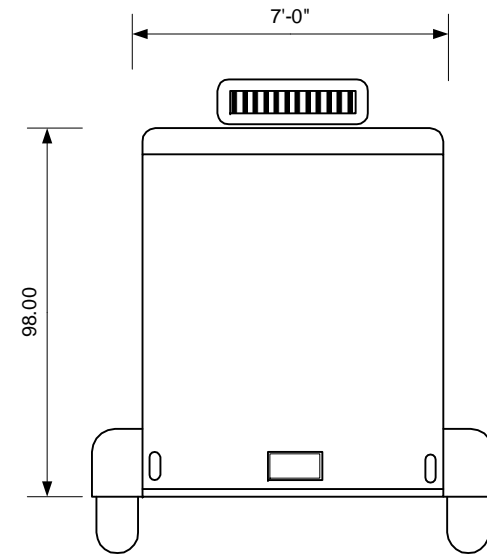
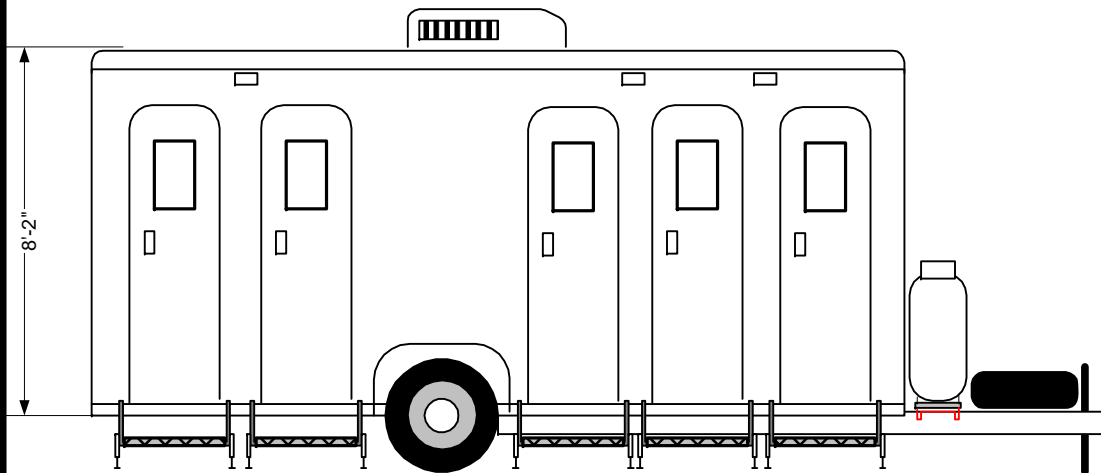
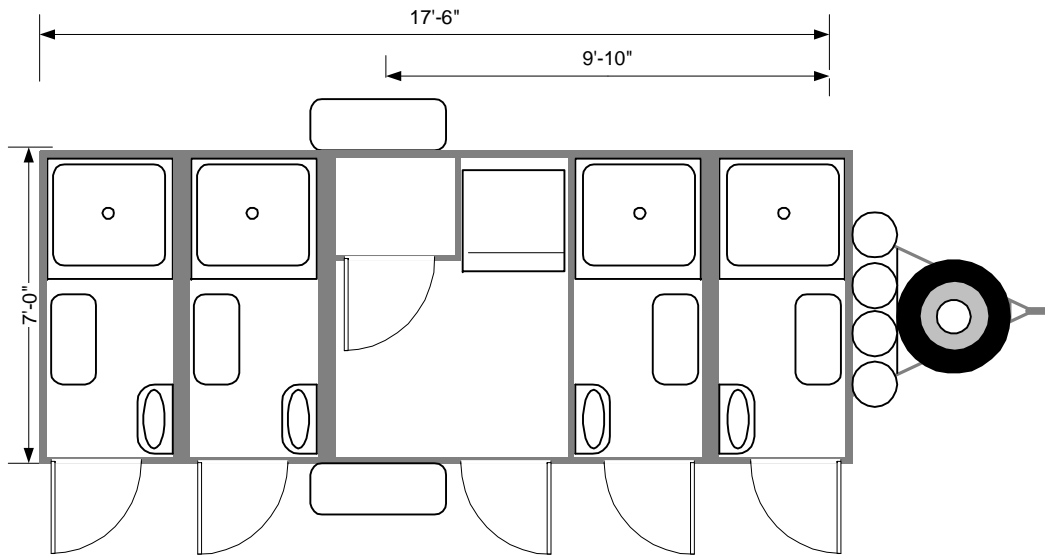

This document is the property of and contains unpublished proprietary information and trade secrets of A.M.S. Global Inc. By accepting possession of the document the recipient agrees to make no copies transcriptions or any use of this document or the information contained herein except as authorized by A.M.S. Global Inc. and further agrees to safe keep this document and return in to A.M.S. Global Inc. upon demand.

Approved by _____



1 7 0 6 6 9 3 8 0 9 8 9

Advanced Performance 18 5S S



- Direct Connect
- Stacked washer drier
- Requires 50amp 240VAC
- Vandal Proof shower heads
- All Stainless steel dispensers
- Propane on demand heated water
- 5 private showers benches & sinks
- Vacant Occupied indicating deadbolts
- metal frame, floor, exterior & all composite wall panels
- Propane demand heated water and 4 40# bottles
- Leveling jacks, fold up steps automatic door closers
- Obscure windows in radius doors with Automatic door closers
- 15,000 BTU A/C and 5500 btu central heat
- 5 - 1500 watt bathroom heaters
- LED 50,000 hour burn lighting and trailer lighting
- 16 Radials and electric brakes & spare

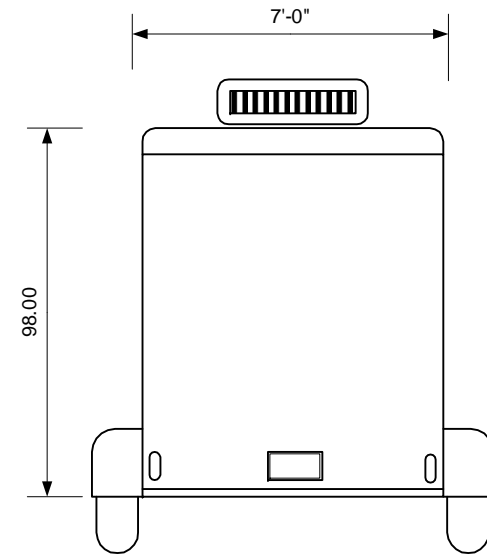
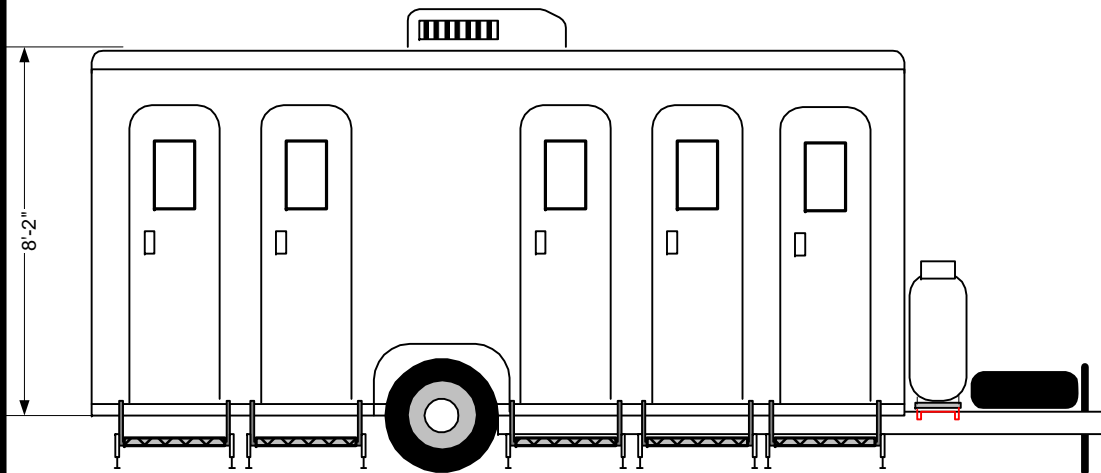
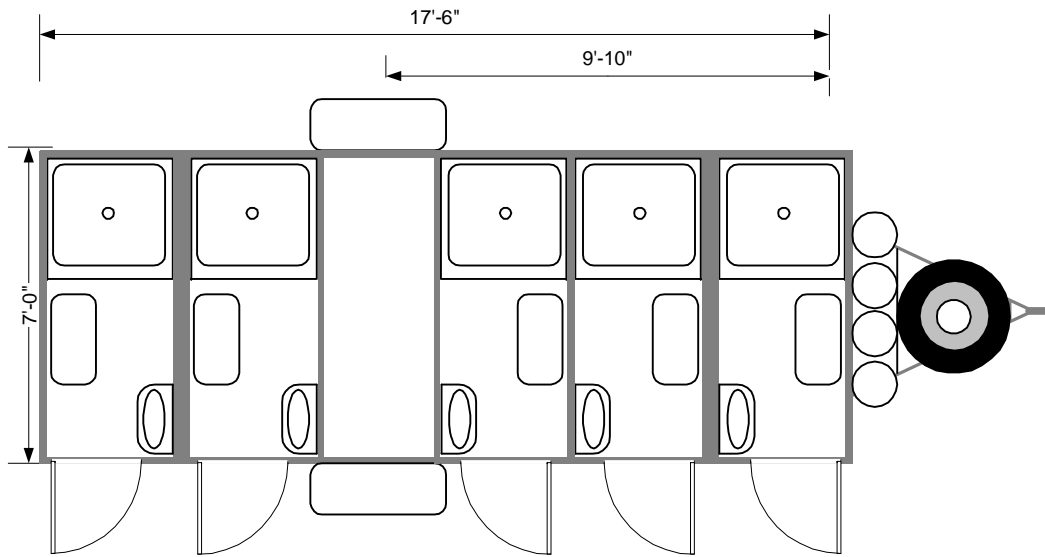

This document is the property of and contains unpublished proprietary information and trade secrets of A.M.S. Global Inc. By accepting possession of the document the recipient agrees to make no copies transcriptions or any use of this document or the information contained herein except as authorized by A.M.S. Global Inc. and further agrees to safe keep this document and return in to A.M.S. Global Inc. upon demand.

Approved by _____



↓ 5 □ 7 30 26 □ 8 ↓ 3

Advanced Performance APF 18 5STS

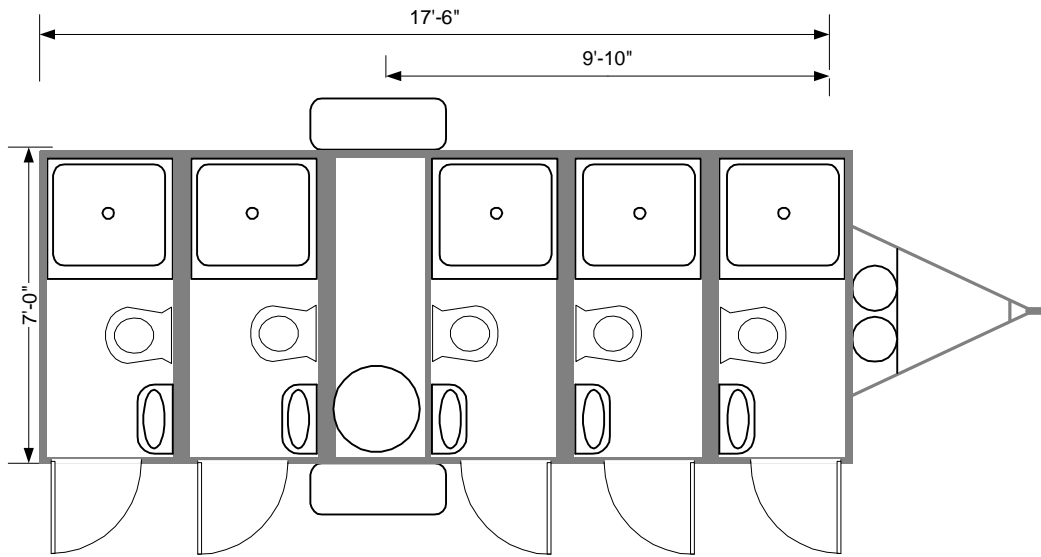

- Requires 30amp 120AC Direct Connect
- Steel frame, floor and exterior and all composite wall panels
- Vandal Proof shower heads
- Propane heated water 50 gallons
- 5 private showers & sinks hot and cold water
- Vacant Occupied indicating deadbolts
- Propane heated water and two 40# bottles
- Leveling jacks, fold up steps & Spare
- Obscure windows in radius doors with Automatic door closers
- 15,000 BTU A/C and 5500 btu heat
- LED 50,000 hour burn lighting and trailer lighting
- Radials and electric brakes

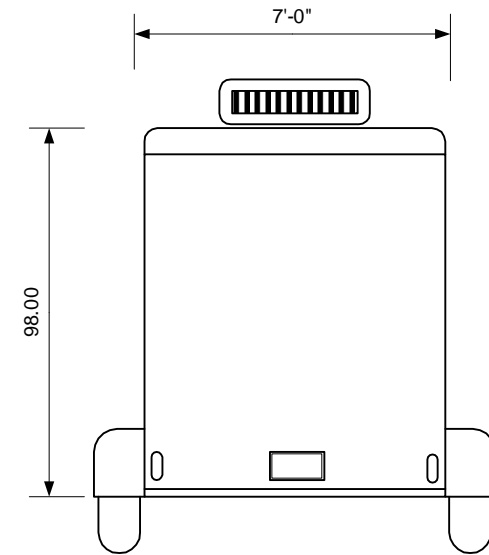
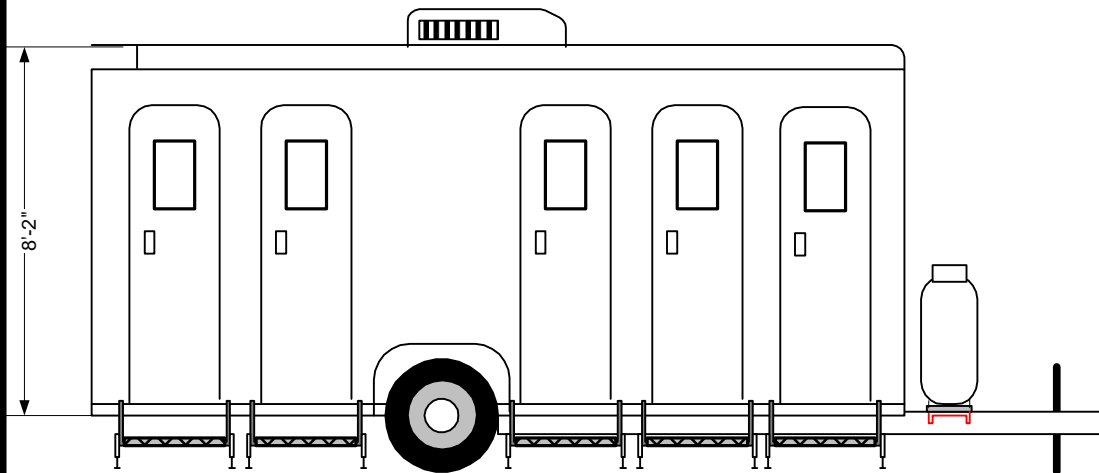

This document is the property of and contains unpublished proprietary information and trade secrets of A.M.S. Global Inc. By accepting possession of the document the recipient agrees to make no copies transcriptions or any use of this document or the information contained herein except as authorized by A.M.S. Global Inc. and further agrees to safe keep this document and return in to A.M.S. Global Inc. upon demand.

Approved by _____



14 53 23 20 90 3

Advanced Performance APF 20 3STS Direct

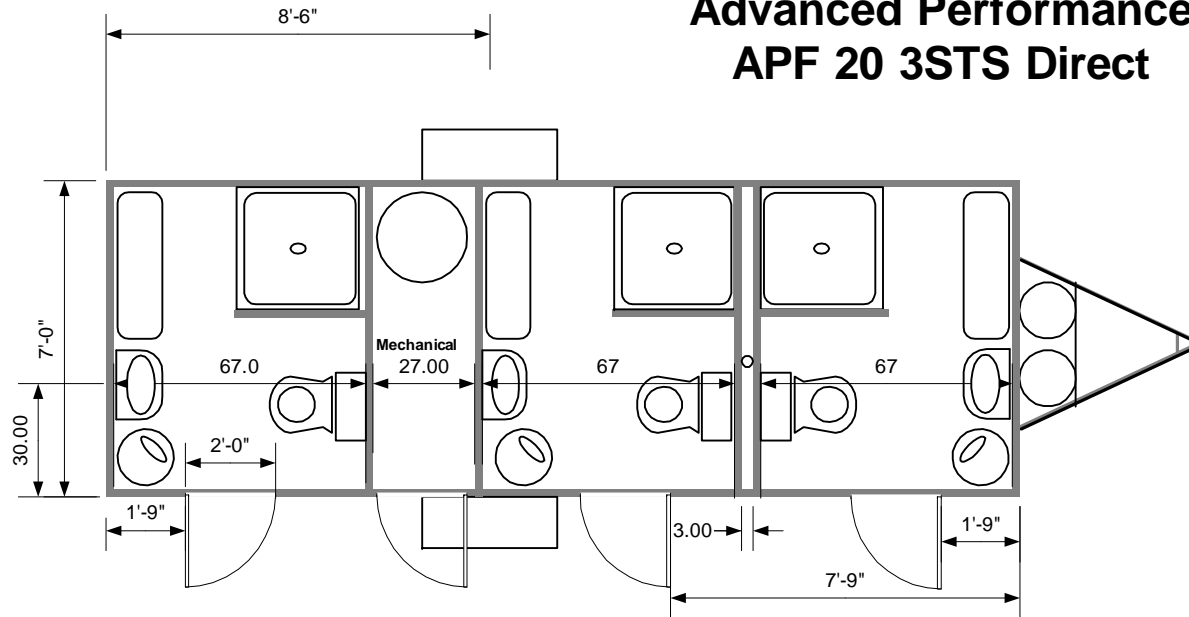

- Requires 50amp 240AC
- Steel frame, floor and exterior
- Vandal Proof shower heads
- Stainless steel soap paper and tissue dispensers
- Framed mirrors
- Electric Brakes 6000# axle
- 3 Toilets 3 sinks 3 benches
- All porcelain wall hung fixtures
- All metal & composite construction
- Vacant Occupied indicating deadbolts
- LP hot water 50 gallons
- 1.5GPM Metered faucets and shower valves
- Obscure windows in radius doors
- Automatic door closers
- Heat & Air Conditioned 15,000BTU AC/5,500 BTU Heat
- LED 50,000 hour burn lighting and trailer lighting
- Direct connect

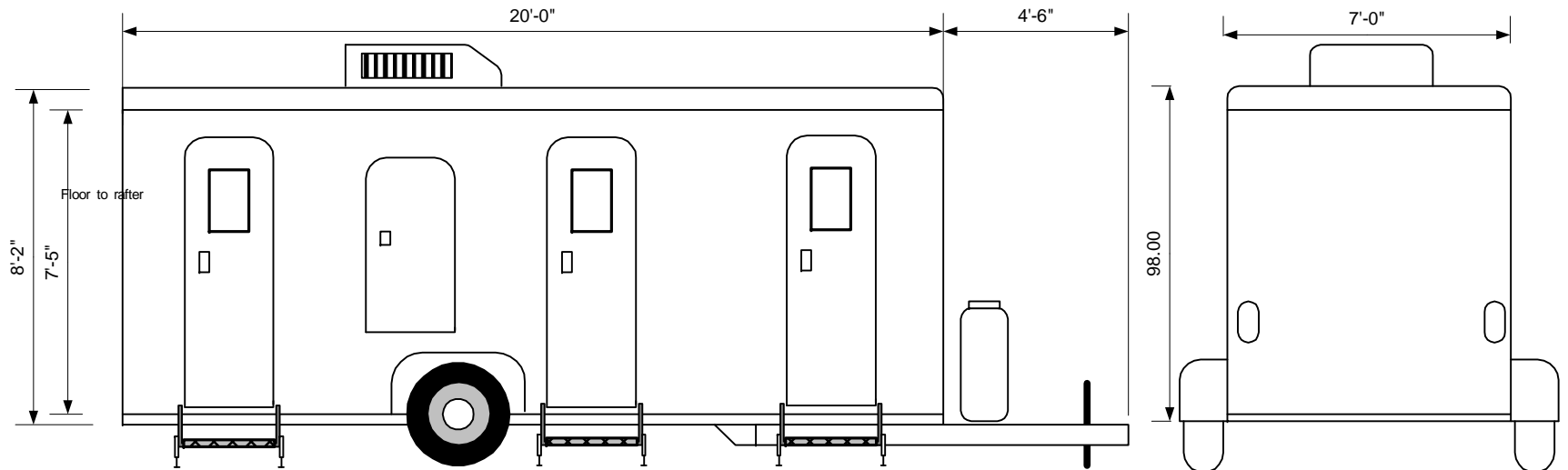

This document is the property of and contains unpublished proprietary information and trade secrets of A.M.S. Global Inc. By accepting possession of the document the recipient agrees to make no copies transcriptions or any use of this document or the information contained herein except as authorized by A.M.S. Global Inc. and further agrees to safe keep this document and return it to A.M.S. Global Inc. upon demand.

Approved by _____



Performance 20 3STS LWD

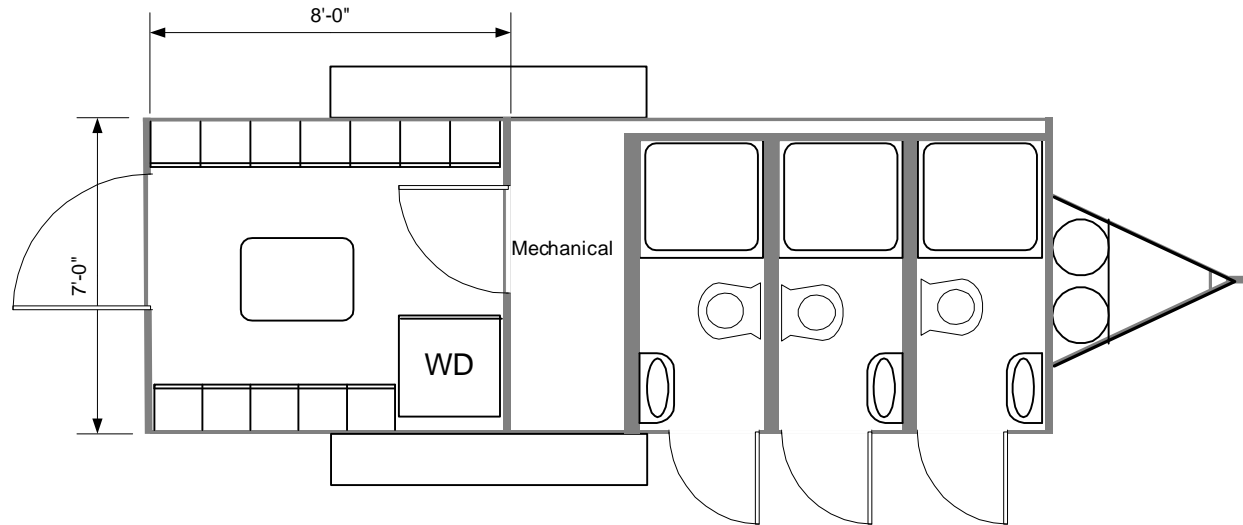

- Requires 50amp 240AC
- Steel frame, floor and exterior
- Vandal Proof shower heads
- Electric Brakes 6000# Double axles
- Uses less than a pint per flush 10NT Vacuumator
- 5 Jets™ Marine Toilets
- All porcelain wall hung fixtures
- All metal & composite construction
- Vacant Occupied indicating deadbolts
- Electric or LP heat on demand hot water
- 1.5GPM Metered faucets and shower valves
- Paper towel, tissue and soap dispensers & Shatterproof mirrors
- Obscure windows in radius doors with Automatic door closers
- Heat & Air Conditioned 15,000BTU AC/5,500 btu Heat
- LED 50,000 hour burn lighting and trailer lighting
- Liquefies all waste paper and hygienic products
- Self Pumping to Sewer Tap up to 100 yards w/10' head 1" line

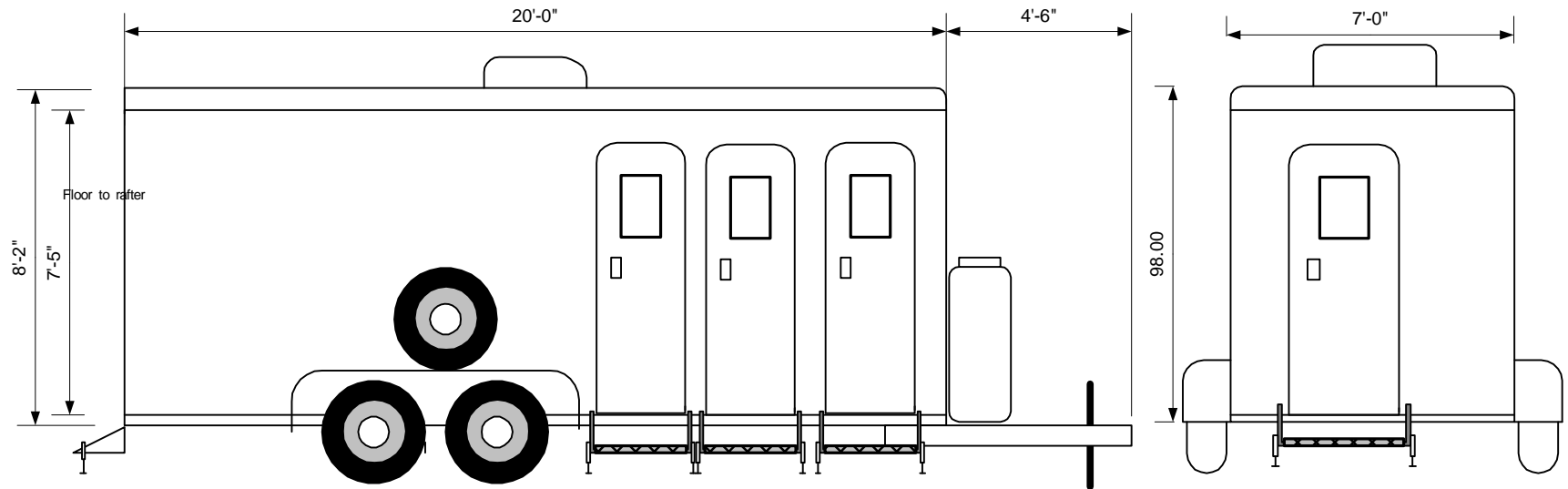

This document is the property of and contains unpublished proprietary information and trade secrets of A.M.S. Global Inc. By accepting possession of the document the recipient agrees to make no copies transcriptions or any use of this document or the information contained herein except as authorized by A.M.S. Global Inc. and further agrees to safe keep this document and return in to A.M.S. Global Inc. upon demand.

Approved by _____



20 49230 633

Advanced Performance 20 4S SWD

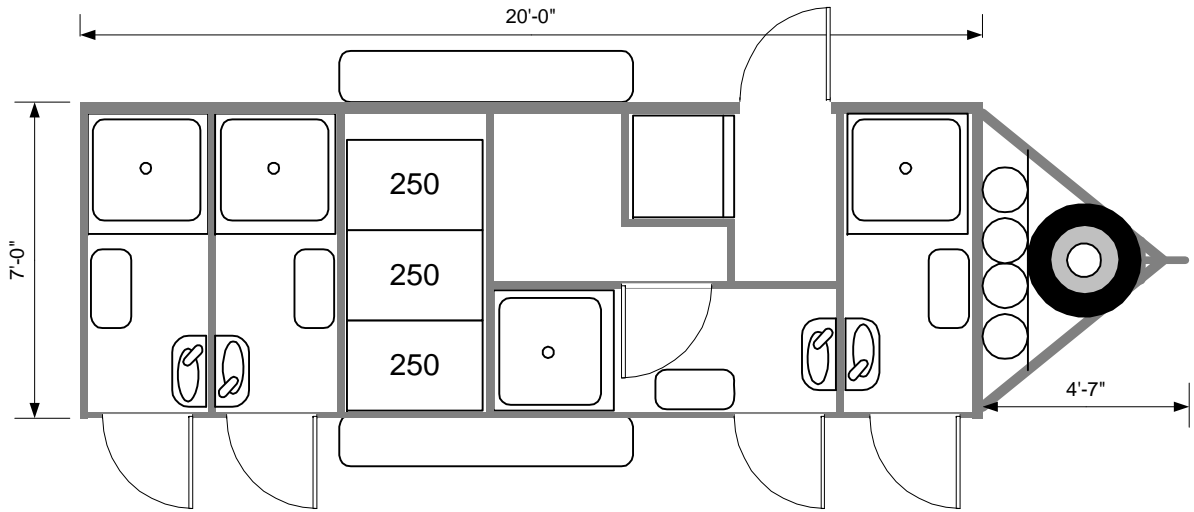

- 750 gallons fresh water storage
- Requires 50amp 240AC
- Steel frame, floor and .040 aluminium exterior
- Vandal Proof shower heads \$ metered faucets
- 4 private showers with benches & sinks
- 5 1500 watt heaters 15,000 btu ducted A/C
- Vacant Occupied indicating deadbolts
- Propane heat on demand hot water and 4 40# bottles
- Leveling jacks, fold up steps & Spare
- Stacked washer drier Stainless dispensers & mirrors
- Obscure windows in radius doors with Automatic door closers
- 4 Turbo vents and all composite wall panels
- LED 50,000 hour burn lighting and trailer lighting
- Dual axes with 16" radials & electric brakes

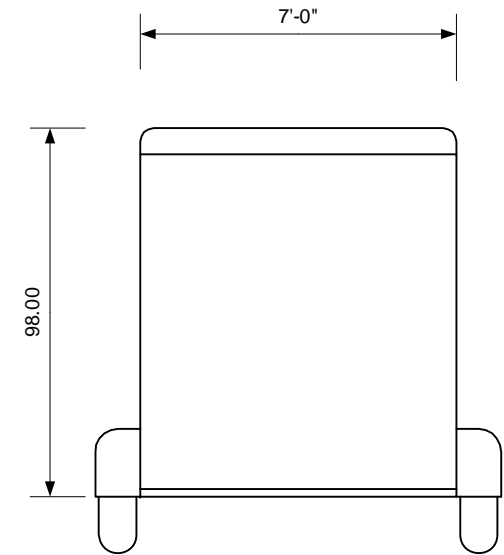
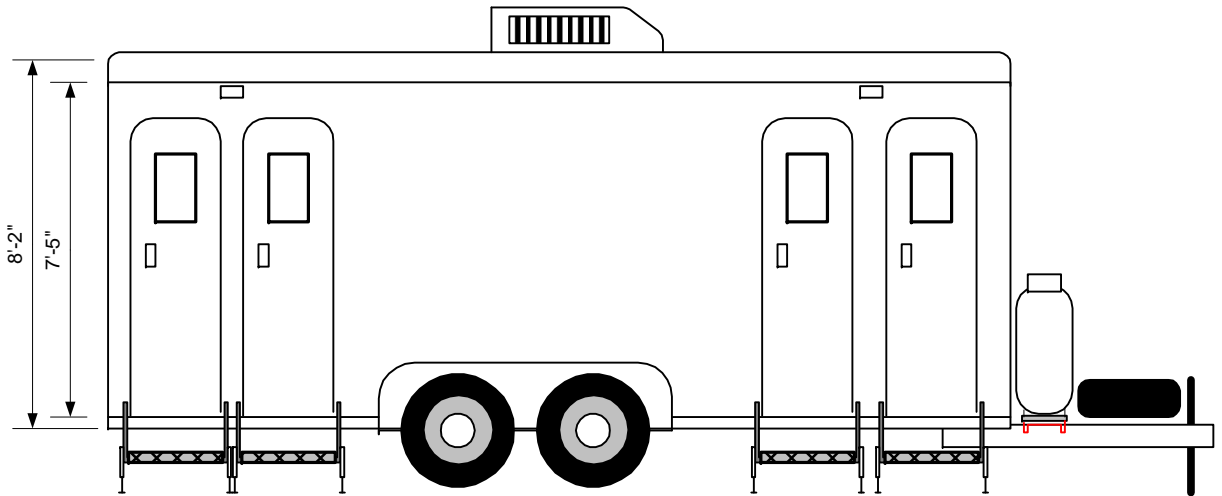

This document is the property of and contains unpublished proprietary information and trade secrets of A.M.S. Global Inc. By accepting possession of the document the recipient agrees to make no copies transcriptions or any use of this document or the information contained herein except as authorized by A.M.S. Global Inc. and further agrees to safe keep this document and return in to A.M.S. Global Inc. upon demand.

Approved by _____



27073640706

Advanced Performance 20 5STS

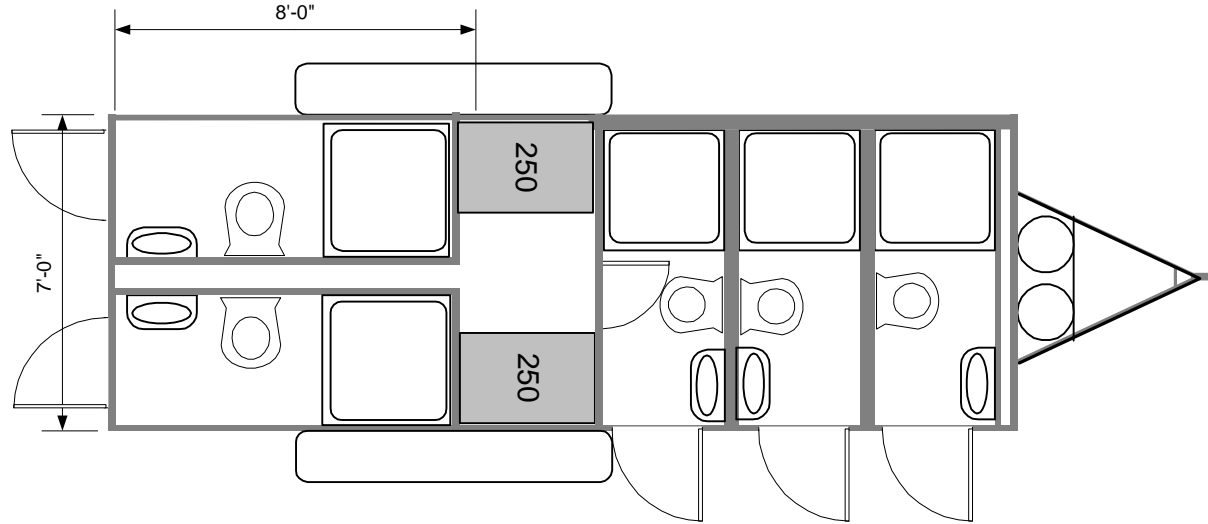

- Requires 50amp 240AC
- Steel frame, floor and exterior .040 aluminum
- Vandal Proof shower heads
- Uses less than a pint per flush
- 5 Jet s™ Marine Toilets & Vacuulator™
- All porcelain wall hung fixtures & 5 power vents
- All metal & composite construction with leveling jacks
- Vacant Occupied indicating deadbolts
- Propane heat on demand hot water and two 40# bottles
- 1.5GPM Metered faucets and shower valves
- SS steel Paper towel, tissue and soap dispensers & mirrors
- Obscure windows in radius doors with Automatic door closers
- Heat & Air Conditioned 15BTU AC/5500 BTU Heat
- LED 50,000 hour burn lighting and trailer lighting
- Liquefiable waste paper and hygienic products
- Self Pumping to Sewer Tap up to 100 yards w/10' head 1" line

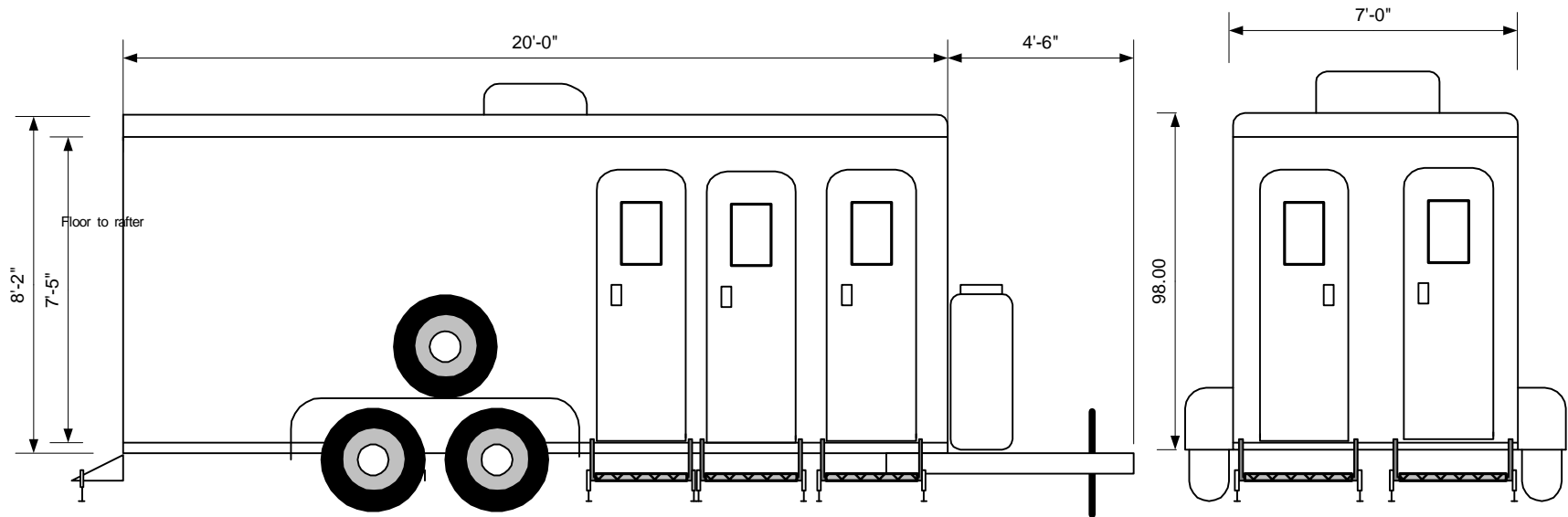

This document is the property of and contains unpublished proprietary information and trade secrets of A.M.S. Global Inc. By accepting possession of the document the recipient agrees to make no copies transcriptions or any use of this document or the information contained herein except as authorized by A.M.S. Global Inc. and further agrees to safe keep this document and return in to A.M.S. Global Inc. upon demand.

Approved by _____



23 9 14 38 860

Advanced Performance 24 2S1T2S 16LC

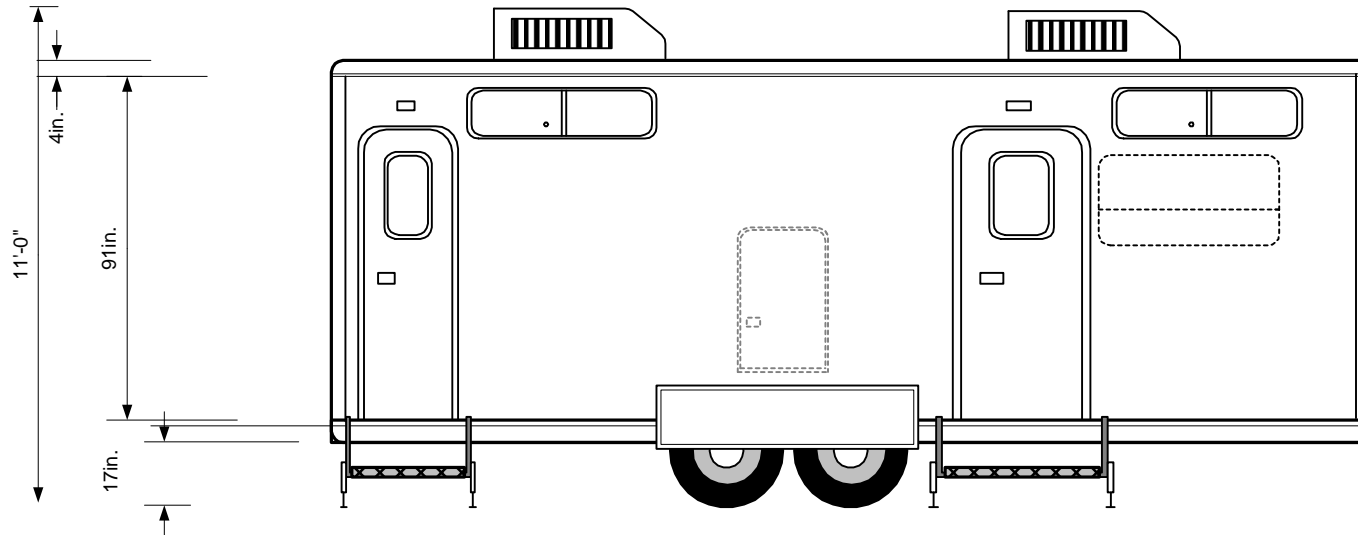

- 16 15x12x36 Locker s or 8 15x12x72
- 2 one step landings with Led porch lights
- Leveling jacks and three windows
- 2 7000 pound axles with electric brakes
- Air Conditioned 30,000 BTU heat 11000btu
- (1) 240 v @ 50 amp AC power required
- Heat on demand metered showers (2)
- All metal and composite construction no wood
- 1 Toilets 2 wall sinks
- Direct connect to sewer
- LED 50,000 hour burn lighting
- Radiused skylight doors and auto closers
- Retractable tounge & Low profile
- 3 benches

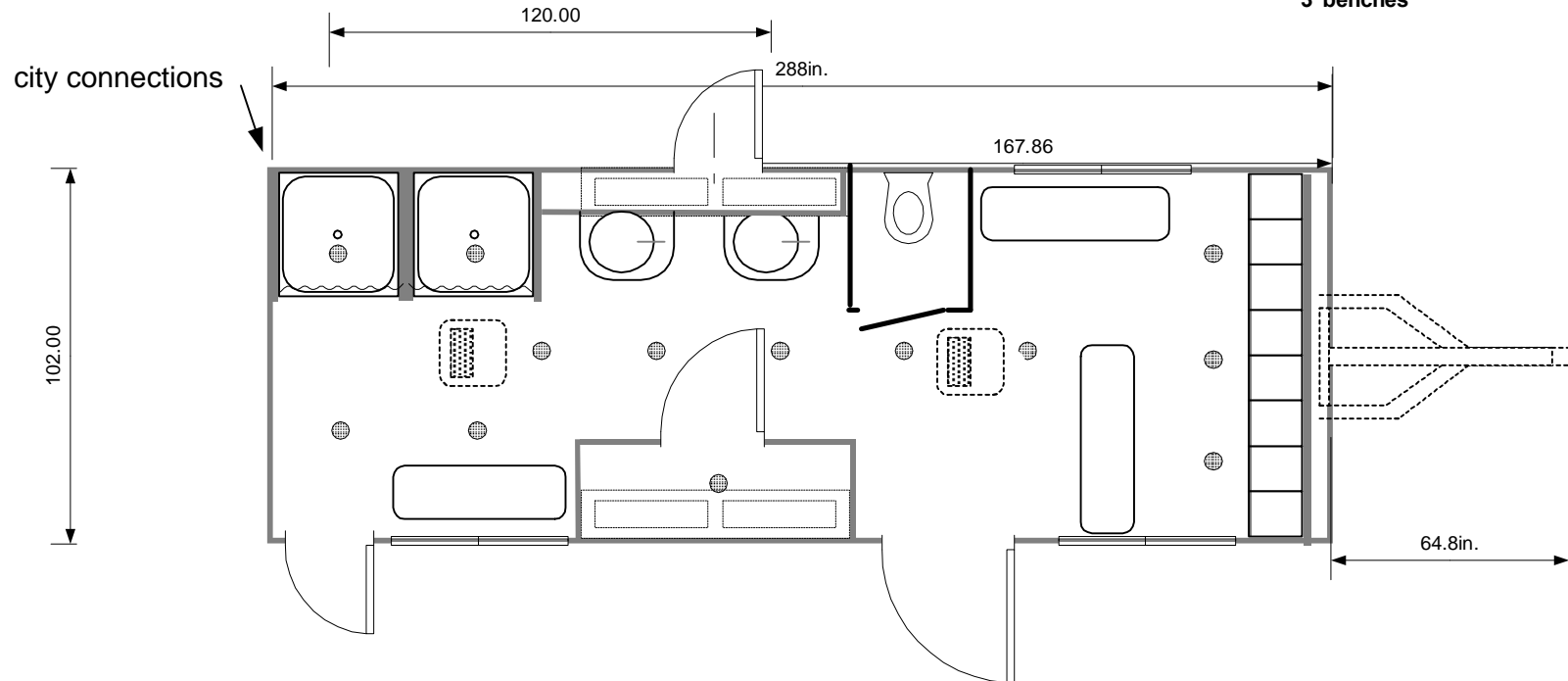

This document is the property of and contains unpublished proprietary information and trade secrets of A.M.S. Global Inc. By accepting possession of the document the recipient agrees to make no copies transcriptions or any use of this document or the information contained herein except as authorized by A.M.S. Global Inc. and further agrees to safe keep this document and return in to A.M.S. Global Inc. upon demand.

Approved by _____

www.AMSglobal.us (877) 789-1213 Copyright 2011 A.M.S. Global Inc. All rights reserved



33 6006 3 1 18

Advanced Performance 24 5STS

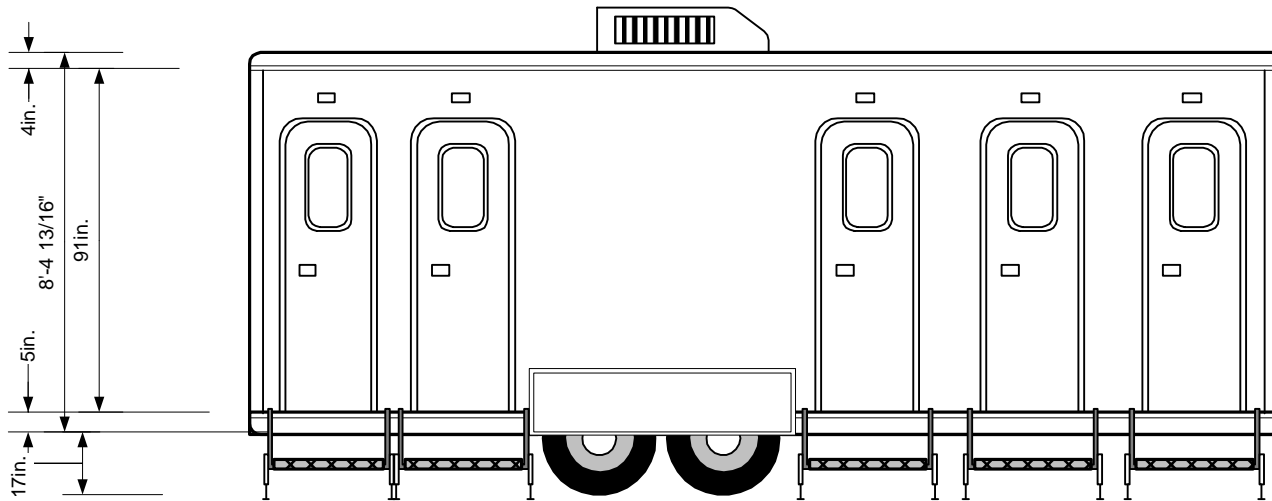

- 5 step landings
- 2 Remote controlled leveling jacks 16,000 lb
- 2 7000 pound axles with electric brakes
- Air Conditioned 15,000 BTU heat 5500
- 5 1500 watt heaters 5 Fantastic Power vents
- 10nt 240 volt CVS™ Jets™ Vacuator™ Pump
- (1) 240 v @ 50 amp AC power required
- LP Heat on demand metered showers & faucets
- All metal and composite construction
- 5 Jets™ Marine Toilets 5 wall sinks
- Stainless steel soap, tissue & towel dispensers
- Optima glass mat battery Retractable tongue
- All metal and composite construction
- 500 gallon waste tank capacity +/- 4000 flushes
- 250 gallon fresh water storage
- Uses less than a quart per flush
- LED 50,000 hour burn lighting
- Radiused skylight doors and auto closers
- Liquefies all waste and paper
- Self Pumping to Sewer Tap
- over 100 feet w/10' head

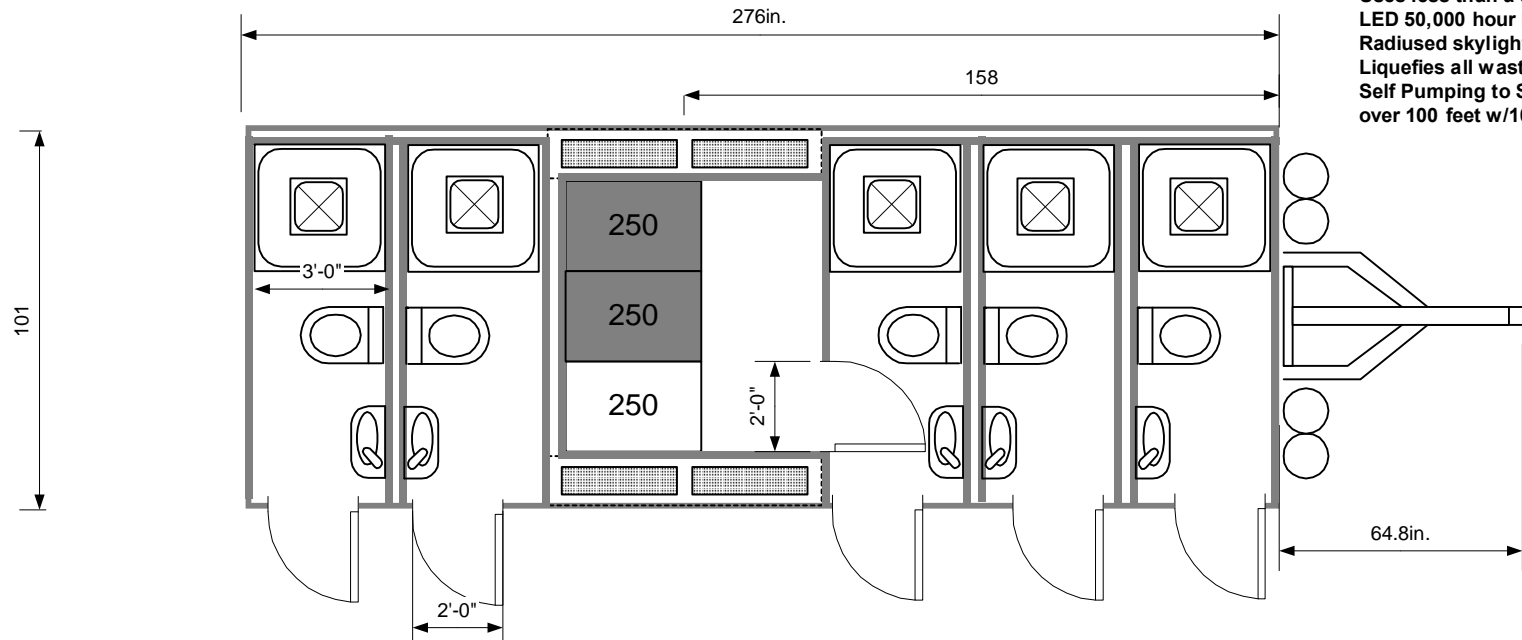

This document is the property of and contains unpublished proprietary information and trade secrets of A.M.S. Global Inc. By accepting possession of the document the recipient agrees to make no copies transcriptions or any use of this document or the information contained herein except as authorized by A.M.S. Global Inc. and further agrees to safe keep this document and return in to A.M.S. Global Inc. upon demand.

Approved by _____

www.AMSglobal.us (877) 789-1213 Copyright 2011 A.M.S. Global Inc. All rights reserved



24 9404 7 294

APF 24 6S S

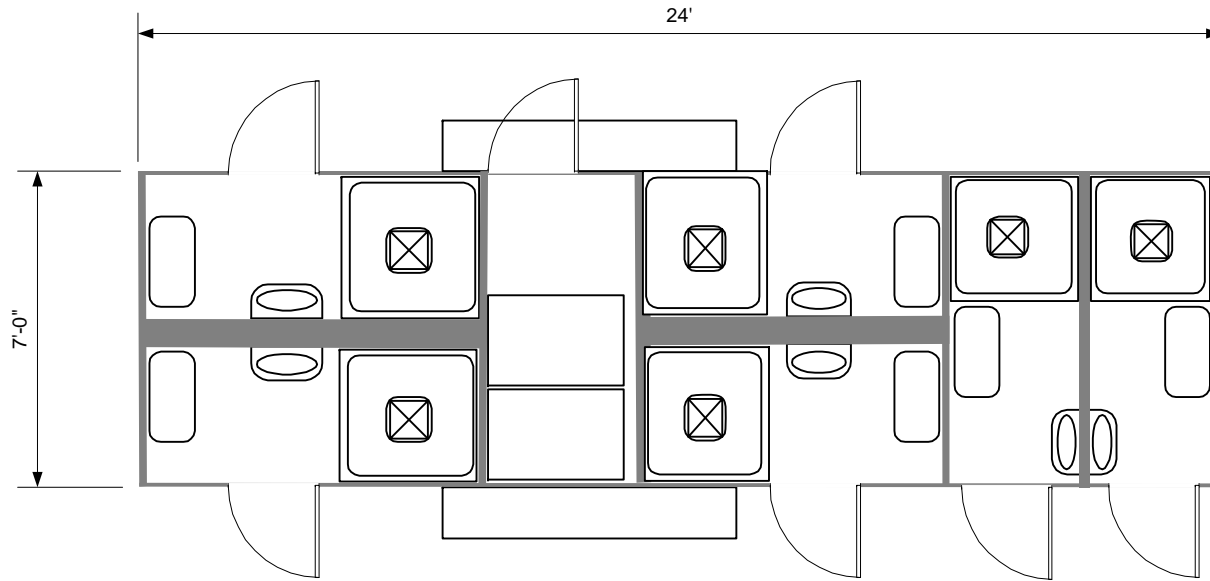

- Steel frame, floor and .04 aluminium exterior
- All composite and metal construction-No Wood
- Vandal Proof shower heads
- 6 Turbo ventilation fans
- All porcelain wall hung sinks
- Vacant Occupied indicating deadbolts
- All led lighting and trailer lights
- Propane heat on demand hot water and two 40# bottles
- 1.5GPM Metered faucets and shower valves
- Stainless Steel towel & soap dispensers
- Framed mirrors
- Obscure windows in radius doors with Automatic door closers
- 500 gallons of water storage
- LED 50,000 hour burn lighting and trailer lighting
- 30amp @120 power required
- 6 stationary benches in shower rooms

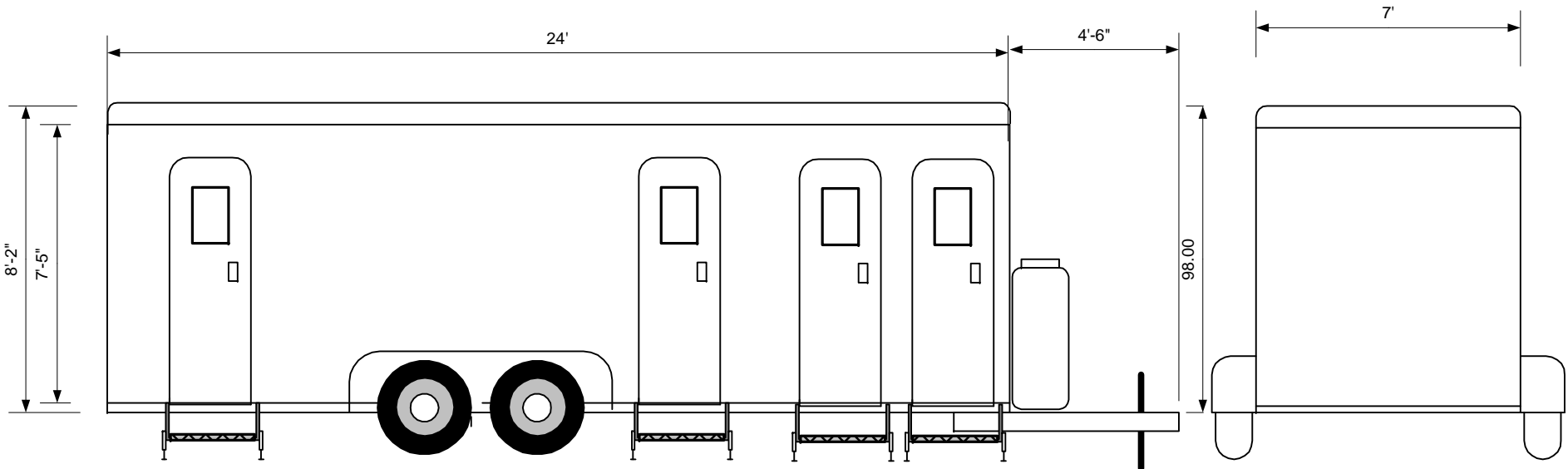

This document is the property of and contains unpublished proprietary information and trade secrets of A.M.S. Global Inc. By accepting possession of the document the recipient agrees to make no copies transcriptions or any use of this document or the information contained herein except as authorized by A.M.S. Global Inc. and further agrees to safe keep this document and return in to A.M.S. Global Inc. upon demand.

Approved by _____



260875460225



28'-0"

24'-0"

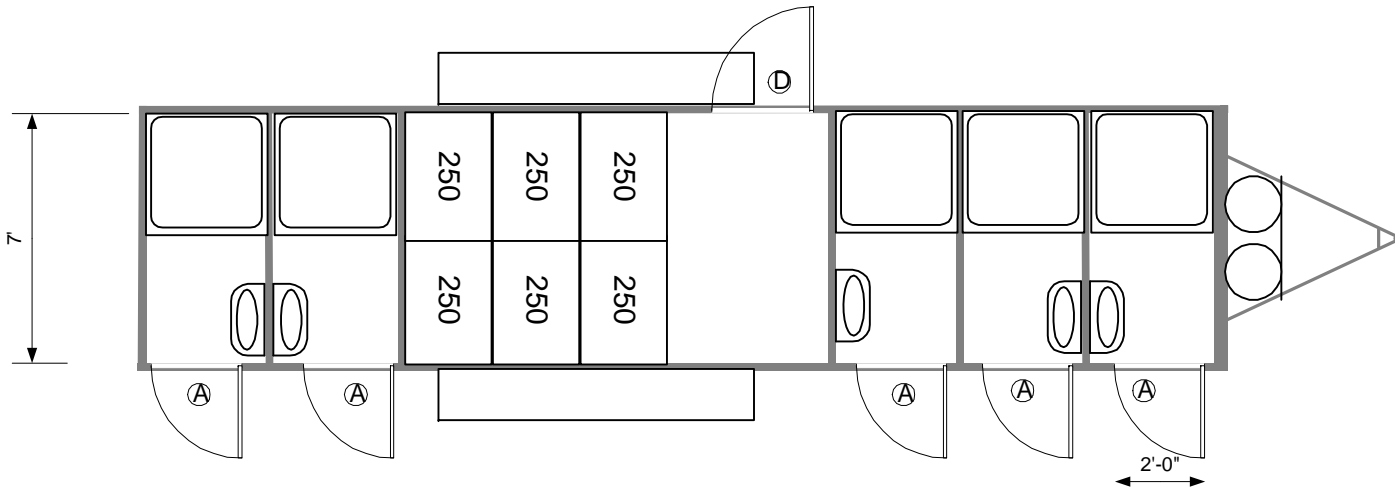

APF 24-5SS

- Leveling Jacks
- Requires 30amp 110AC
- Steel frame and exterior
- 1500 gallons fresh water storage
- Vandal proof sewer heads
- Propane heat on demand hot water
- Dual axles and spare
- Metered shower valves
- Obscure windows in radius doors
- 2 Heat & Air Conditioned 15,000BTU
- LED 50,000 hour burn lighting
- All porcelain wall hung fixtures

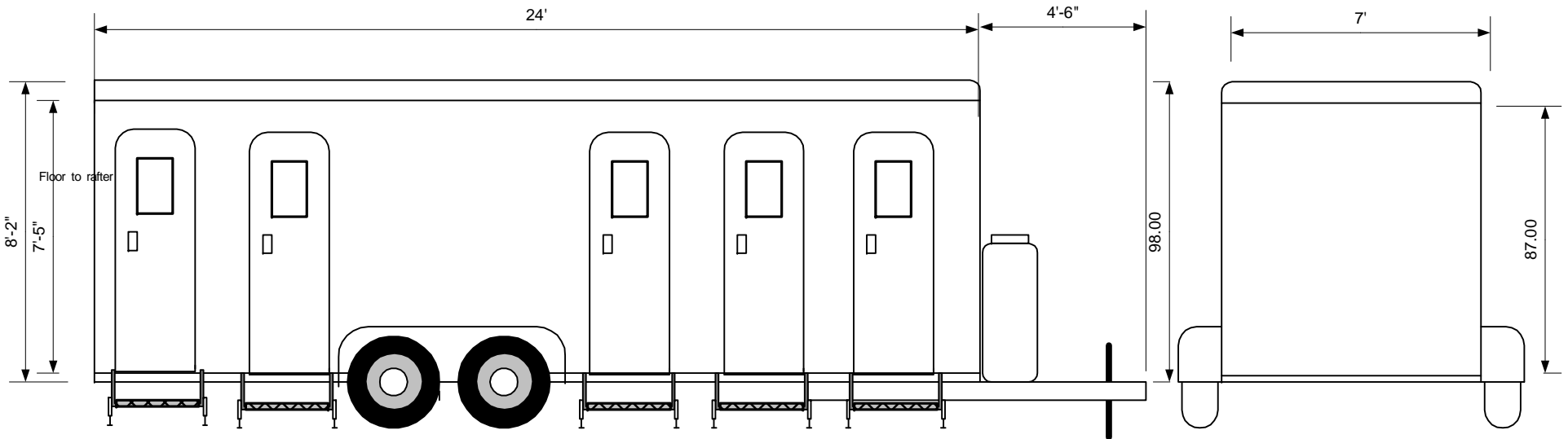

This document is the property of and contains unpublished proprietary information and trade secrets of A.M.S. Global Inc. By accepting possession of the document the recipient agrees to make no copies transcriptions or any use of this document or the information contained herein except as authorized by A.M.S. Global Inc. and further agrees to safe keep this document and return in to A.M.S. Global Inc. upon demand.



Approved by _____



21 21 24 50 769

Advanced Performance 28 1SS Cooler Office

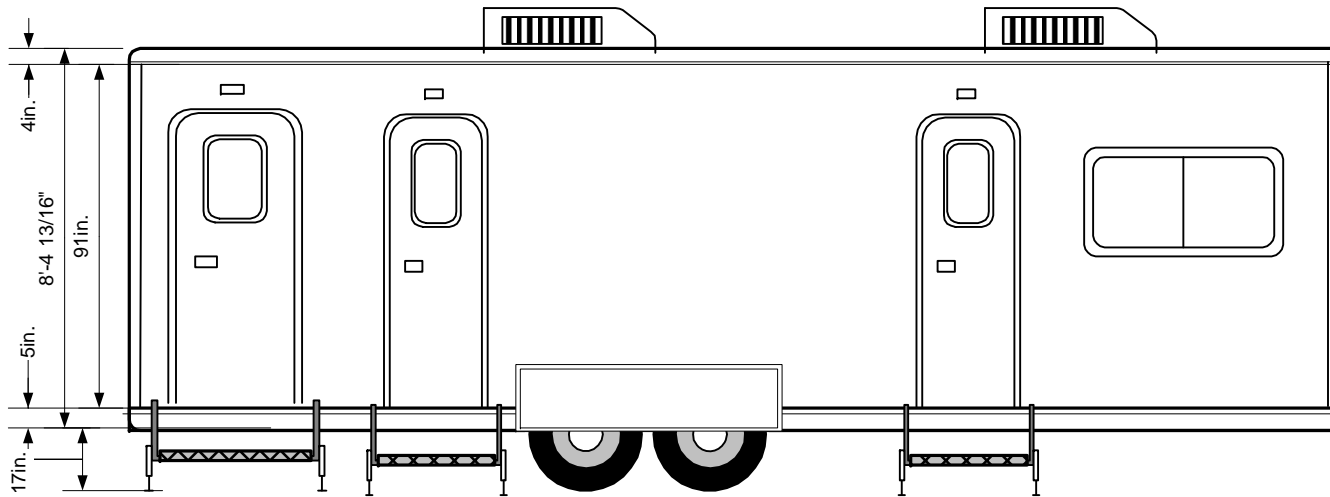

- All metal and composite construction
- 3 step landings & 4 leveling jacks
- 2 7000 pound axles with electric brakes
- Air Conditioned 30,000 BTU heat 11000
- (1) 240 v @ 50 amp AC power required
- 375 gallon water tank capacity
- 250 gallon fuel storage
- LED 50,000 hour burn lighting
- Radiused skylight doors and auto closers
- 2 cooling benches over tires
- 1 ANSI Drench shower & eyewash
- Gold Stainless Steel pump
- Constantly stirred temperature controlled water tanks
- Generator platform & 2' x 4' window

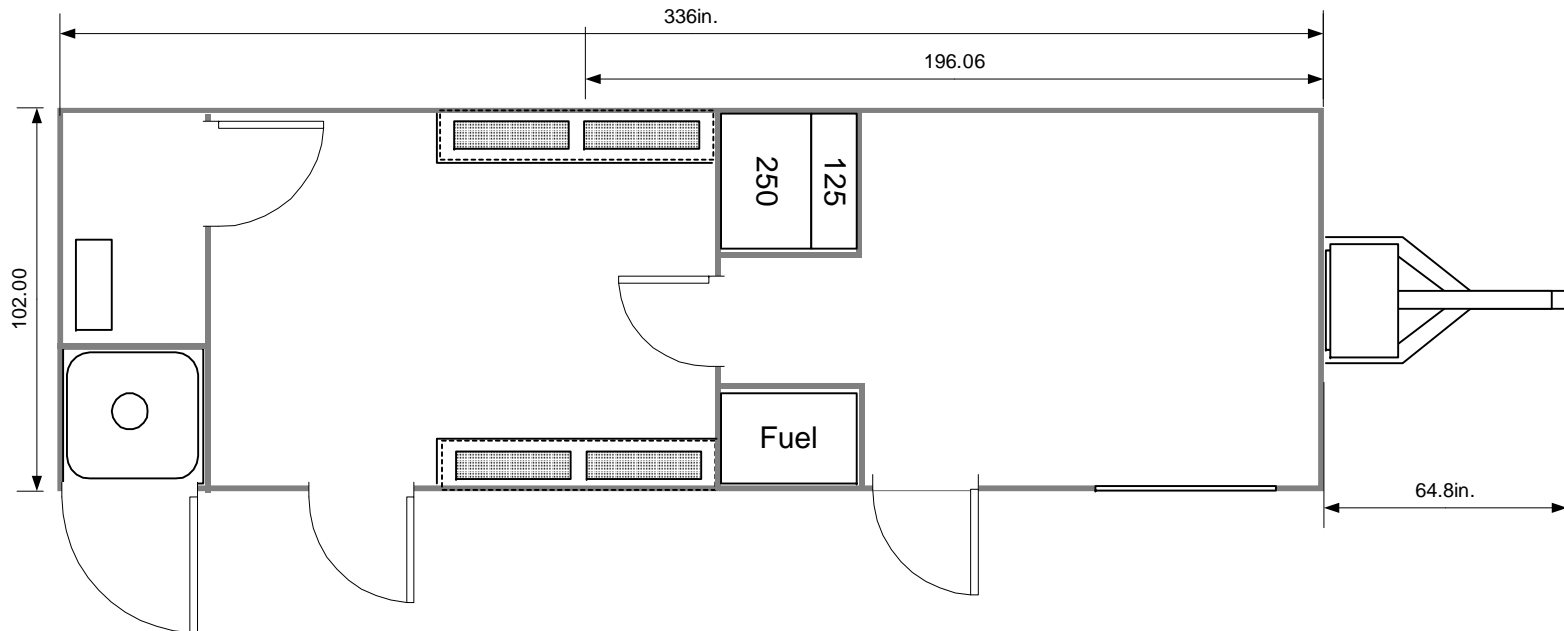

This document is the property of and contains unpublished proprietary information and trade secrets of A.M.S. Global Inc. By accepting possession of the document the recipient agrees to make no copies transcriptions or any use of this document or the information contained herein except as authorized by A.M.S. Global Inc. and further agrees to safe keep this document and return in to A.M.S. Global Inc. upon demand.

Approved by _____

www.AMSglobal.us (877) 789-1213 Copyright 2011 A.M.S. Global Inc. All rights reserved



250914490334

Advanced Performance 28 2S1T2S 20LC + Office Advanced Performance 24 2S1T2S 16LC

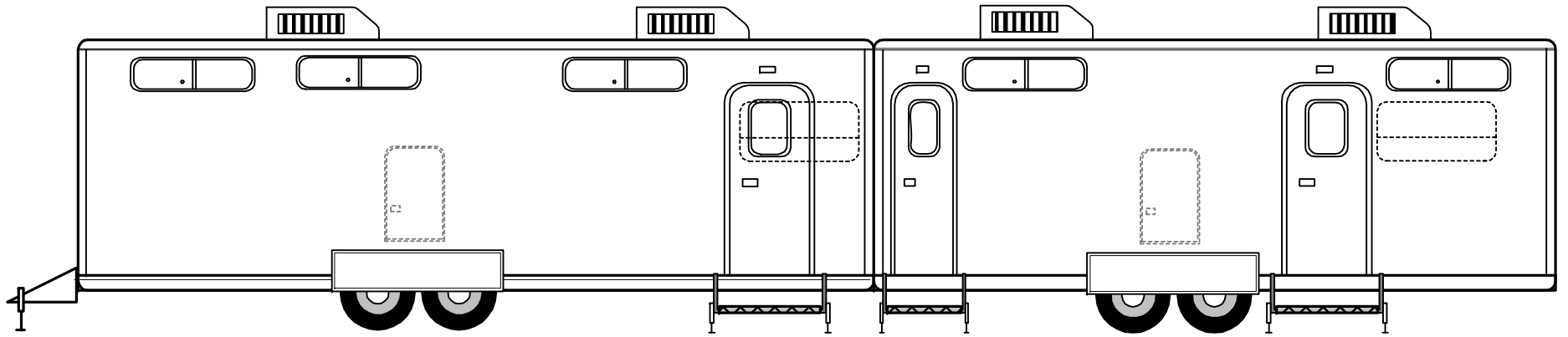

52'

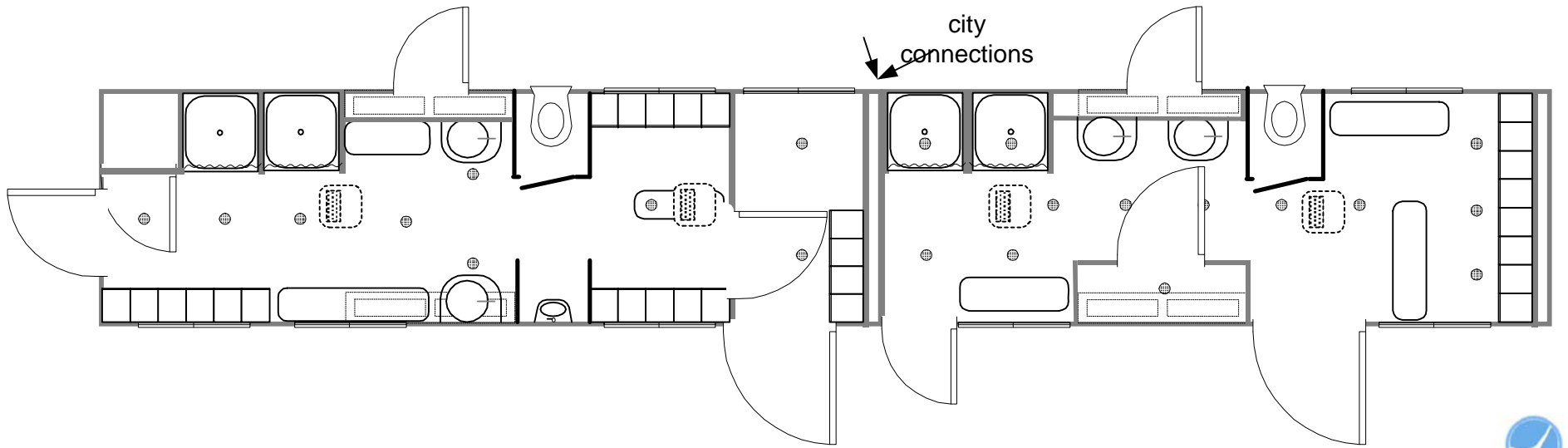

This document is the property of and contains unpublished proprietary information and trade secrets of A.M.S. Global Inc. By accepting possession of this document the recipient agrees to make no copies, transcriptions or any use of this document or the information contained herein except as authorized by A.M.S. Global Inc. and further agrees to safe keep this document and return it to A.M.S. Global Inc. upon demand.

Approved by _____

www.AMSglobal.us (877) 789-1213 Copyright 2011 A.M.S. Global Inc. All rights reserved



250914490334

Advanced Performance 28 2S1T2S 20LC + Office

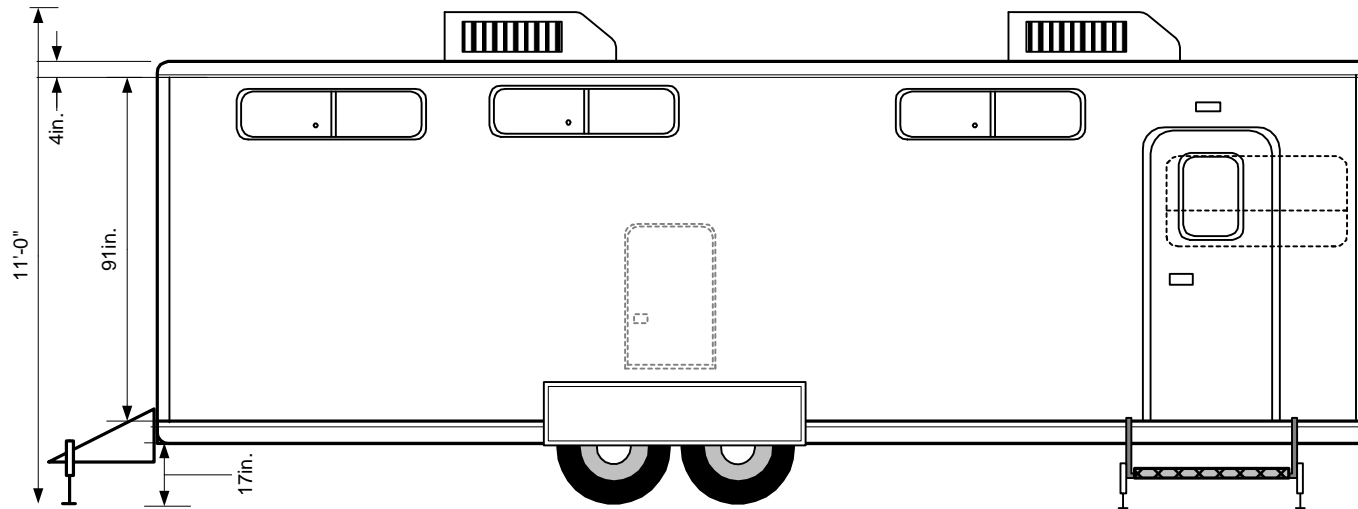

- 40 15x12x36 Lockers or 20 15x12x72
- 2 one step landings with Led porch lights
- Leveling jacks and five windows
- 2 7000 pound axles with electric brakes
- Air Conditioned 30,000 BTU heat 1/4000Vh
- (1) 240 v @ 50 amp AC power required
- Heat on demand metered showers (2)
- All metal and composite construction no wood
- 1 Toilets 2 wall sinks
- Direct connect to sewer
- LED 10,000 hour burn lighting
- Radiused skylight doors and auto closers
- Retractable tounge & Low profile
- 3 benches

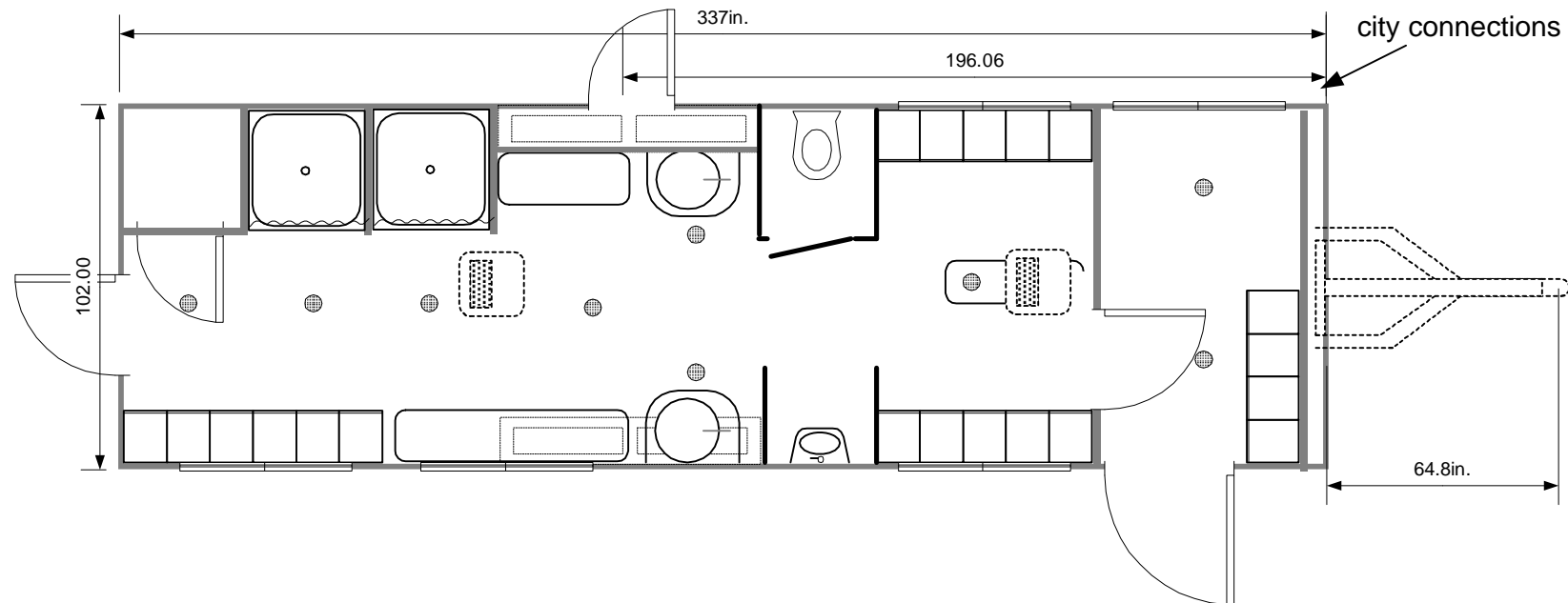

This document is the property of and contains unpublished proprietary information and trade secrets of A.M.S. Global Inc. By accepting possession of the document the recipient agrees to make no copies transcriptions or any use of this document or the information contained herein except as authorized by A.M.S. Global Inc. and further agrees to safe keep this document and return in to A.M.S. Global Inc. upon demand.

Approved by _____

www.AMSglobal.us (877) 789-1213 Copyright 2011 A.M.S. Global Inc. All rights reserved



250914490334

Advanced Performance 28 2S1T2S 20LC + Office

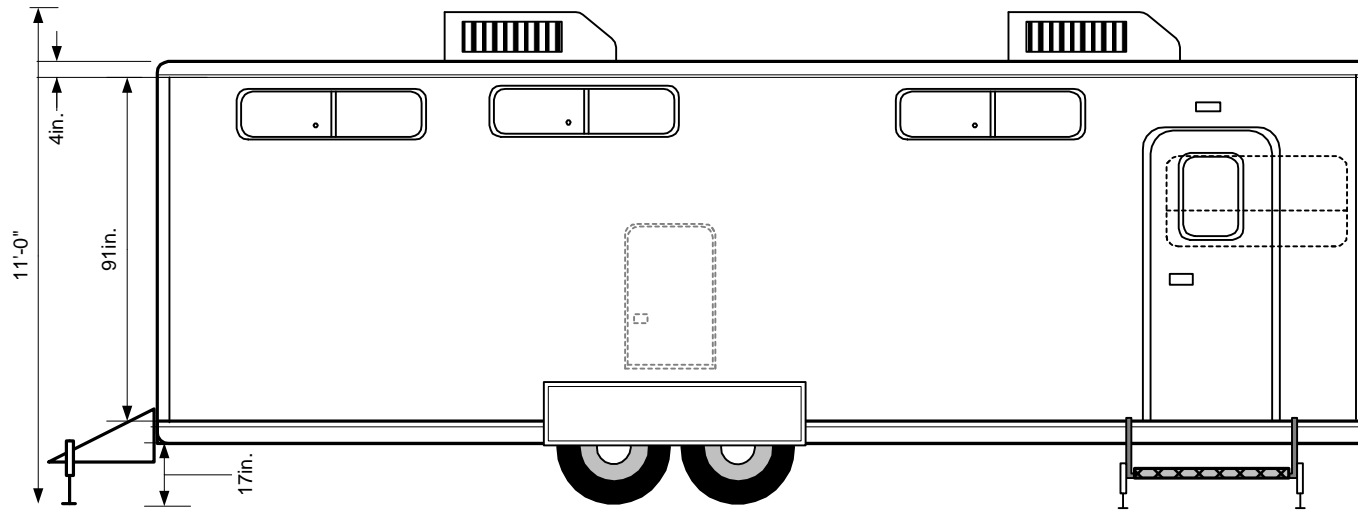

- 40 15x12x36 Locker s or 20 15x12x72
- 2 one step landings with Led porch lights
- Leveling jacks and five windows
- 2 7000 pound axles with electric brakes
- Air Conditioned 30,000 BTU heat 11000btu
- (1) 240 v @ 50 amp AC power required
- Heat on demand metered showers (2)
- All metal and composite construction no wood
- 1 Toilets 2 wall sinks
- Direct connect to sewer
- LED 50,000 hour burn lighting
- Radiused skylight doors and auto closers
- Retractable tounge & Low profile
- 3 benches

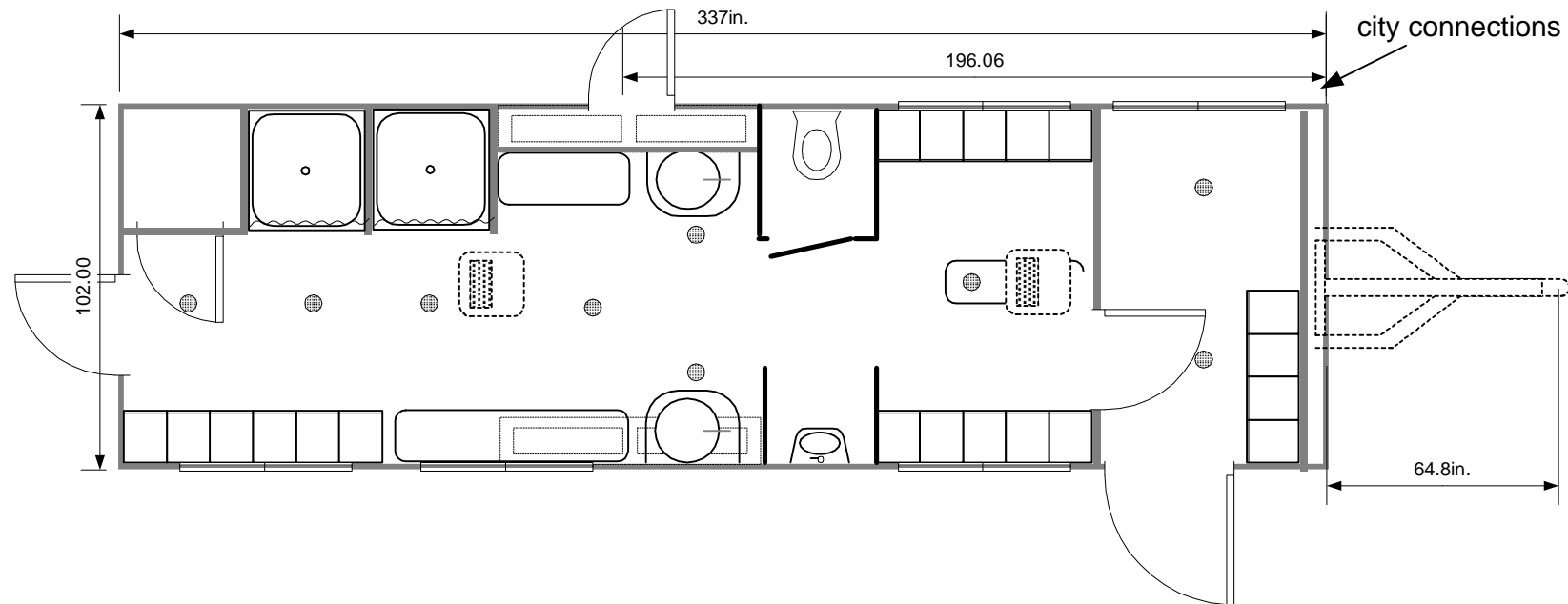

This document is the property of and contains unpublished proprietary information and trade secrets of A.M.S. Global Inc. By accepting possession of the document the recipient agrees to make no copies transcriptions or any use of this document or the information contained herein except as authorized by A.M.S. Global Inc. and further agrees to safe keep this document and return in to A.M.S. Global Inc. upon demand.

Approved by _____

www.AMSglobal.us (877) 789-1213 Copyright 2011 A.M.S. Global Inc. All rights reserved



25 9 144 9 334

Advanced Performance 28 2ST6S 20LC + Break

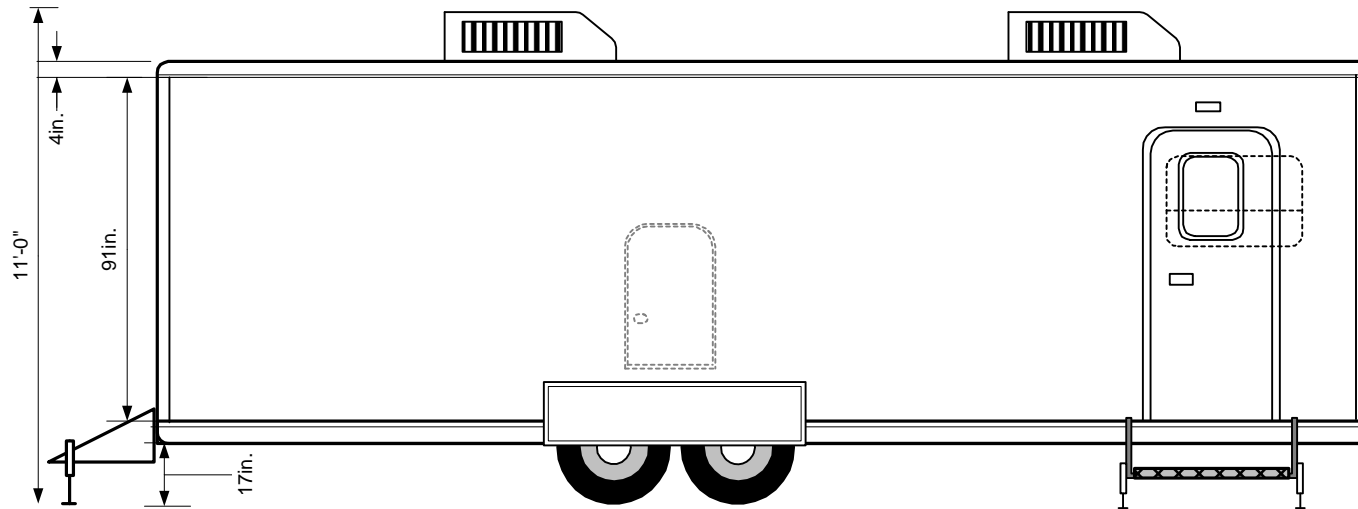

- 20 15x12x36 Lockers
- 2 one step landings with Led porch lights
- leveling jacks rear and one 2x3' window
- 2 electric 4000 pound front jacks
- 2 7000 pound axles with electric brakes
- Air Conditioned 30,000 BTU heat 11000btu
- 10 NT 12 volt VOD Jets Vacumerator Pump
- (1) 240 v @ 50 amp AC power required
- Heat on demand metered showers (6)
- All metal and composite construction no wood
- 2 Jets™ Marine Toilets Vacumerator™ 2 sinks
- Optima glass mat battery
- Direct connect to sewer
- Uses a pint of water per flush
- LED 50,000 hour burn lighting
- Radiused skylight doors and auto closers
- Liquefies all waste and paper
- Self Pumping to Sewer Tap over 100 feet
- Retractable tongue & Low profile
- Bar sink. cabinets & Skylight doors

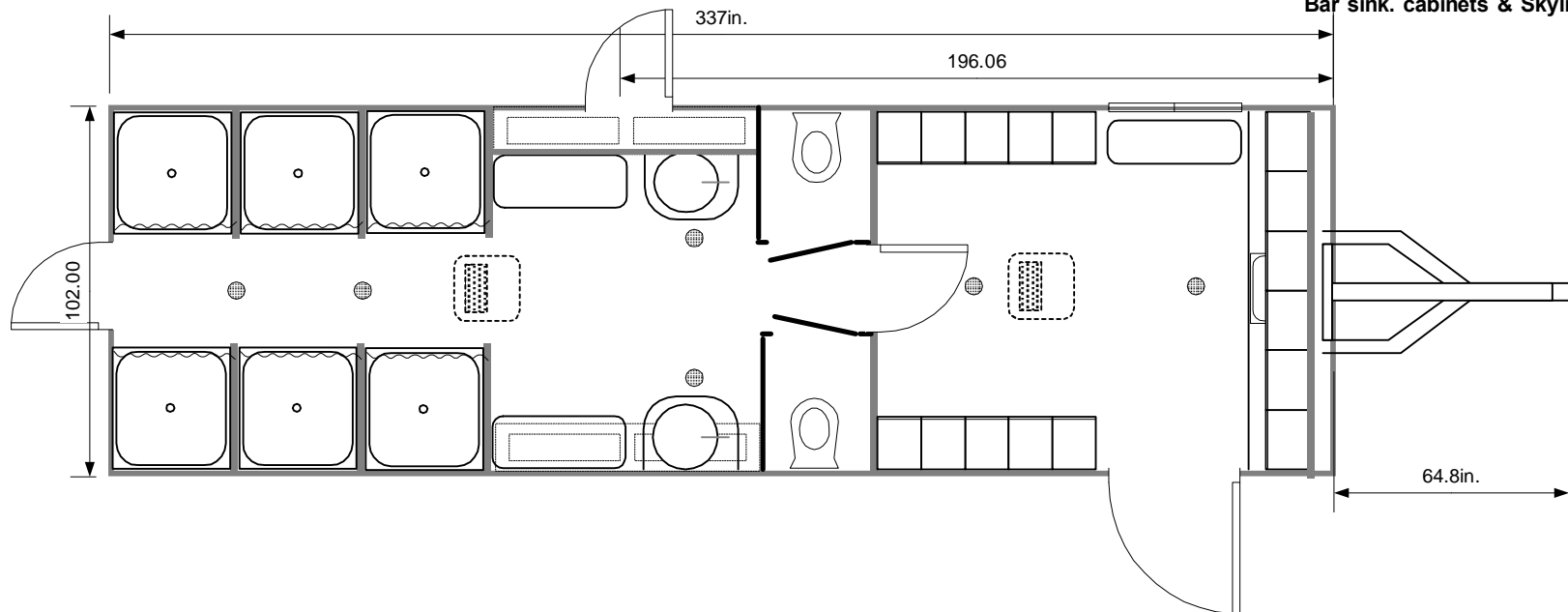

This document is the property of and contains unpublished proprietary information and trade secrets of A.M.S. Global Inc. By accepting possession of the document the recipient agrees to make no copies transcriptions or any use of this document or the information contained herein except as authorized by A.M.S. Global Inc. and further agrees to safe keep this document and return in to A.M.S. Global Inc. upon demand.

Approved by _____

www.AMSglobal.us (877) 789-1213 Copyright 2011 A.M.S. Global Inc. All rights reserved



370601690765

Advanced Performance 28 2STS 20LC

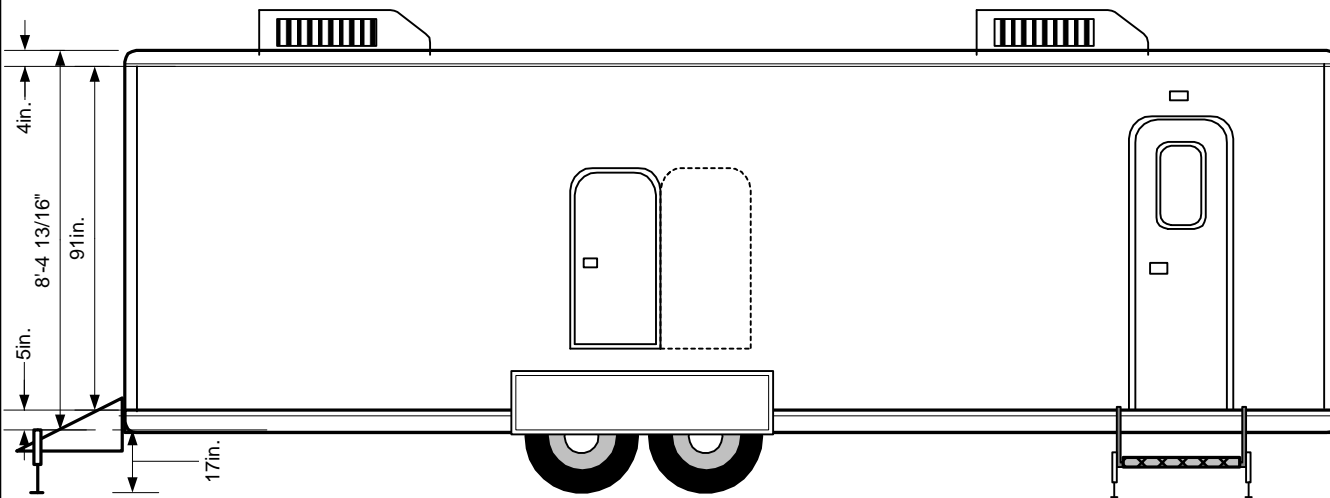

- 20 15x12x6 Zephyr Combination Lockers
- 10 NT Jets Vacuumator™ and 2 Jet s™ toilets
- 125 gallon rotationally molded waste tank (1000 flushes +)
- 3 one step landings & 2 rear leveling jacks
- 2 4000 L B electric Attwood front jacks
- 2 7000 pound axles with electric brakes
- Air Conditioned 30,000 BTU, heat 11000btu internal
- 6 1250 w Broan 154 ceiling heaters with thermostats
- 240 v @ 50 amp AC power required
- Heat on demand metered showers & faucets
- All metal and composite construction .040 alum. exterior
- 2 bath sinks Kitchen break area sink with cabinets
- LED 50,000 hour burn lighting
- Radiused skylight doors and auto closers 7 deadbolts
- 1.5" square tubing walls all composite and steel
- Radiant barrier double foil R15 rated
- Weblon insulated underpinning
- No wood & all electric
- Granitized tread steel floor
- Retractable tongue

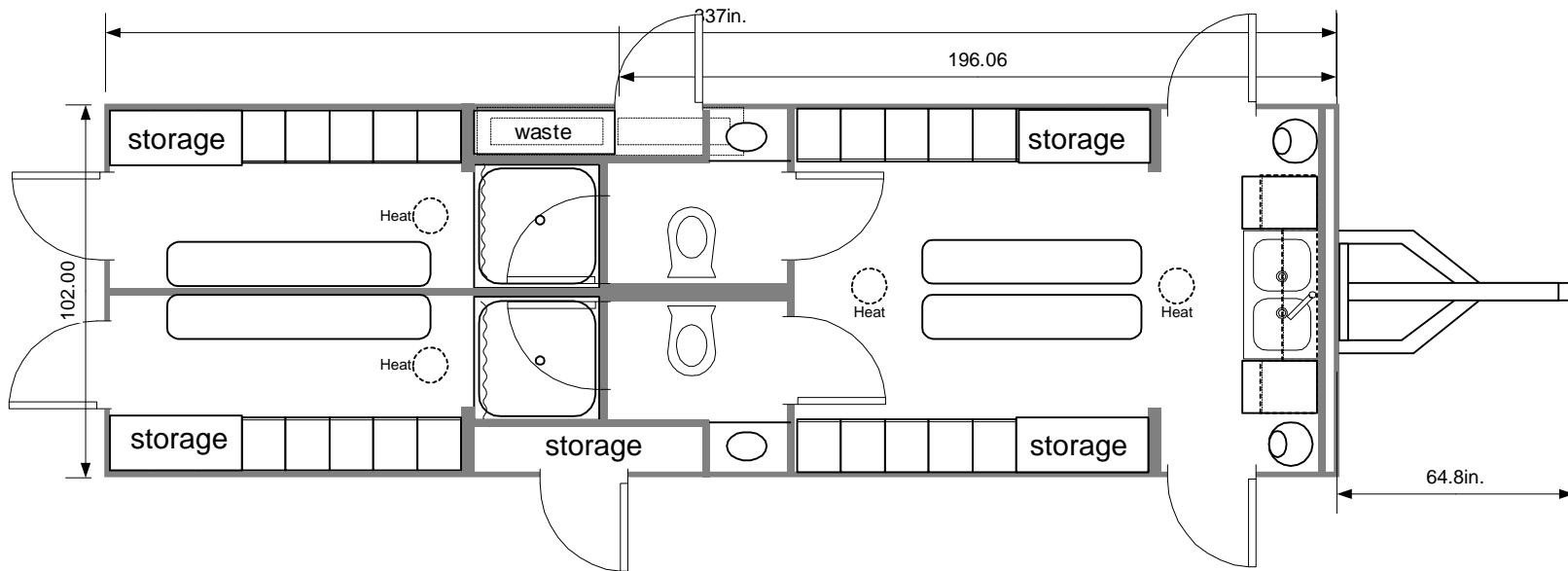

This document is the property of and contains unpublished proprietary information and trade secrets of A.M.S. Global Inc. By accepting possession of the document the recipient agrees to make no copies transcriptions or any use of this document or the information contained herein except as authorized by A.M.S. Global Inc. and further agrees to safe keep this document and return it to A.M.S. Global Inc. upon demand.

Approved by _____

www.AMSglobal.us (877) 789-1213 Copyright 2011 A.M.S. Global Inc. All rights reserved



450369890895

Advanced Performance 28 2STS 32LC + Break

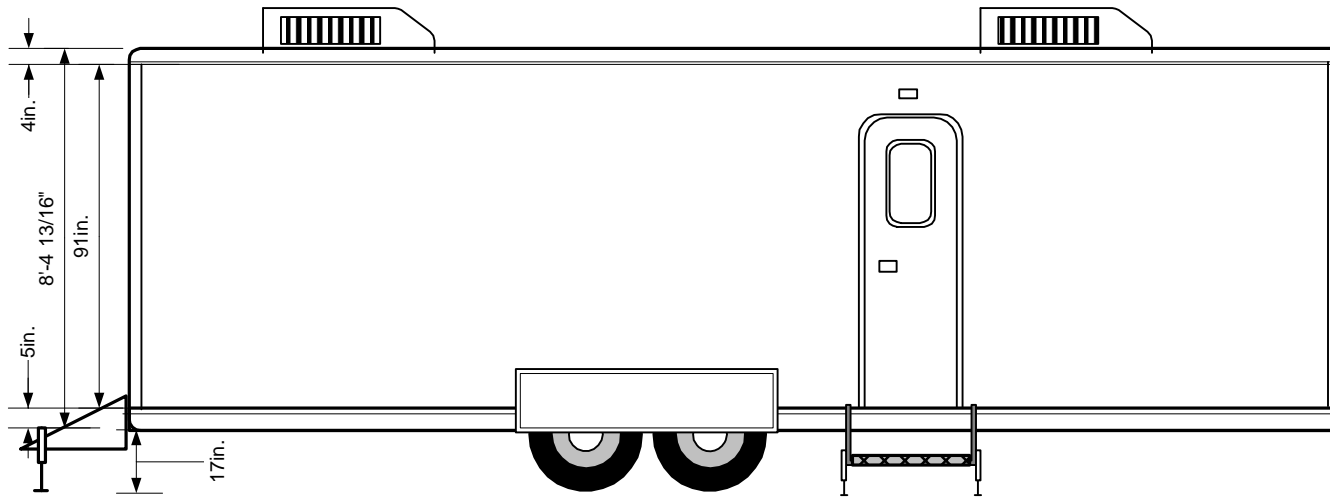

- 32 15x12x48 Lockers
- 3 one step landings
- leveling jacks
- 2 6000 pound axles with electric brakes
- Air Conditioned 30,000 BTU heat 11000
- 1MB 12 volt CVS Jets Vacumerator Pump
- (1) 240 v @ 50 amp AC power required
- Heat on demand metered showers & faucets
- All metal and composite construction
- 2 Jets Marine Vacumerator Toilets 2 wall sinks
- Optima glass mat battery
- Direct connect to sewer
- Uses a pint of water per flush
- LED 50,000 hour burn lighting
- Radiused skylight doors and auto closers
- Liquefies all waste and paper
- Self Pumping to Sewer Tap
- over 100 feet w/10' head
- Retractable tounge Kitchen sink & cabinets

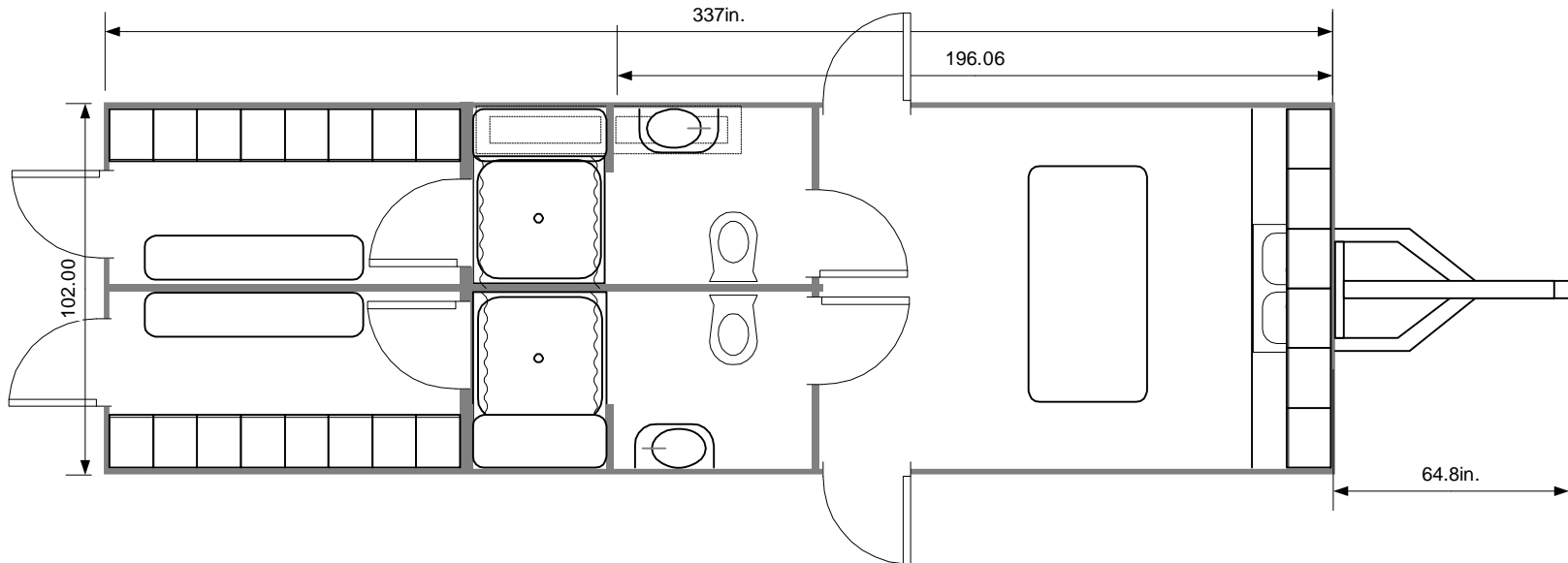

This document is the property of and contains unpublished proprietary information and trade secrets of A.M.S. Global Inc. By accepting possession of the document the recipient agrees to make no copies transcriptions or any use of this document or the information contained herein except as authorized by A.M.S. Global Inc. and further agrees to safe keep this document and return in to A.M.S. Global Inc. upon demand.

Approved by _____

www.AMSglobal.us (877) 789-1213 Copyright 2011 A.M.S. Global Inc. All rights reserved



450369890895

Advanced Performance 28 2STS 52LC

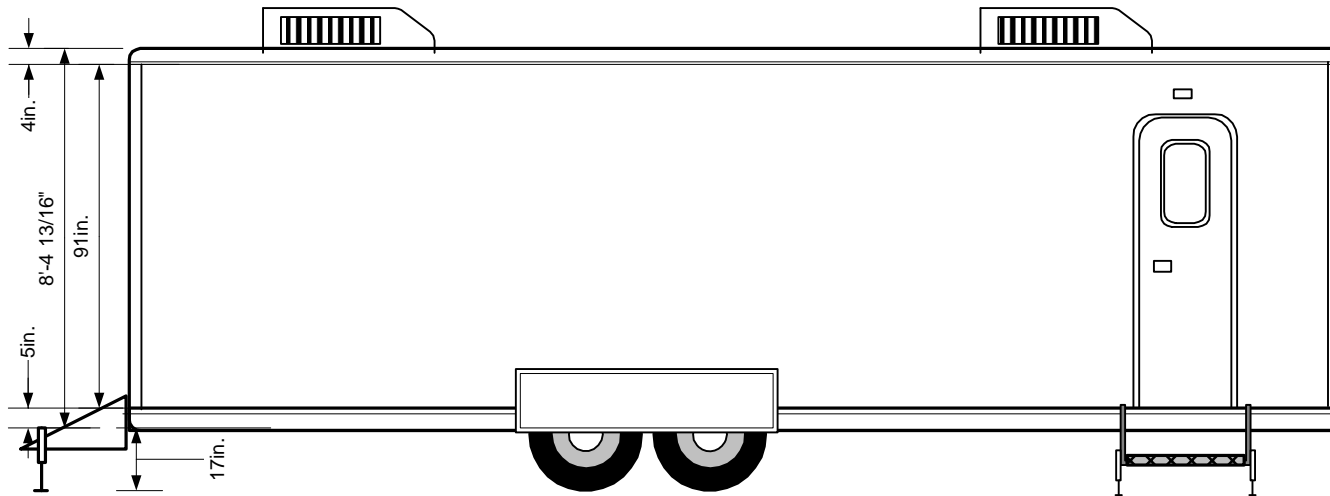

- 52 15x12x48 Lockers
- 3 one step landings
- leveling jacks
- 2 7000 pound axles with electric brakes
- Air Conditioned 30,000 BTU heat 11000
- 10MB 12 volt CVS Jets Vacuerator Pump
- (1) 240 v @ 50 amp AC power required
- Heat on demand metered showers & faucets
- All metal and composite construction
- 2 Jets Marine Vacuerator Toilets 2 wall sinks
- Optima glass mat battery
- Direct connect to sewer
- Uses a pint of water per flush
- LED 50,000 hour burn lighting
- Radiused skylight doors and auto closers
- Liquefies all waste and paper
- Self Pumping to Sewer Tap
- over 100 feet w/10' head
- Retractable tongue

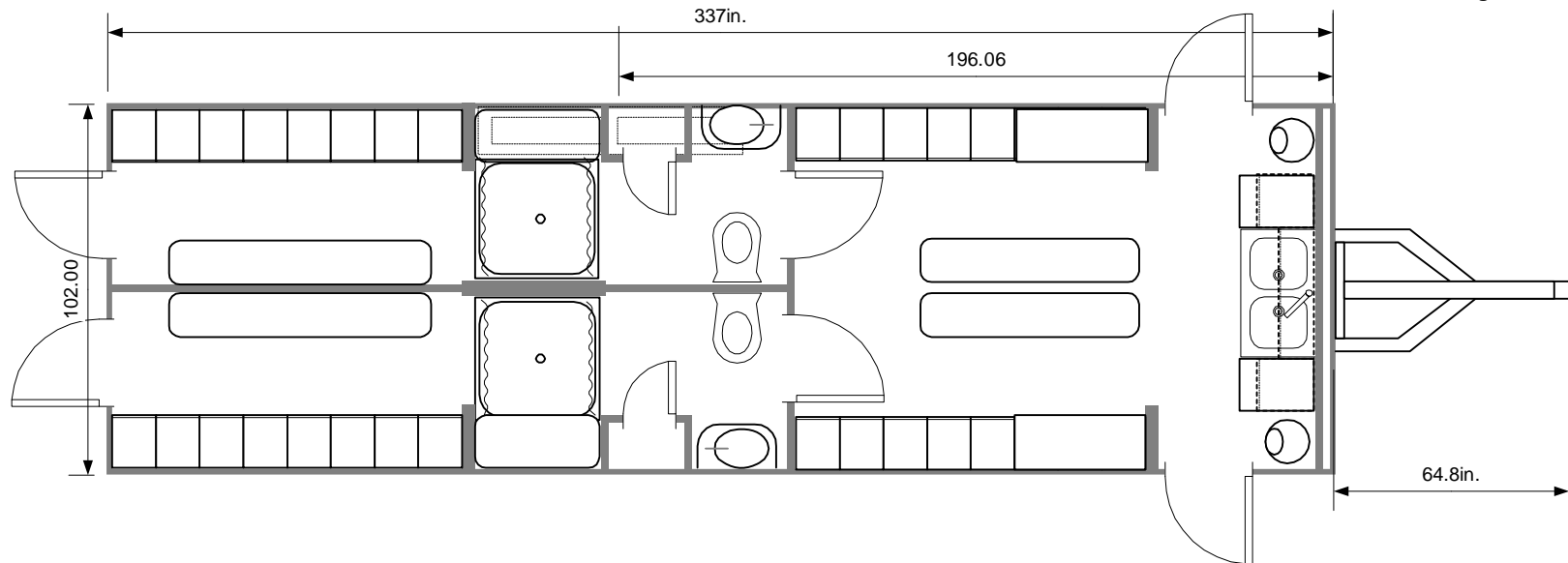

This document is the property of and contains unpublished proprietary information and trade secrets of A.M.S. Global Inc. By accepting possession of the document the recipient agrees to make no copies transcriptions or any use of this document or the information contained herein except as authorized by A.M.S. Global Inc. and further agrees to safe keep this document and return in to A.M.S. Global Inc. upon demand.

Approved by _____

www.AMSglobal.us (877) 789-1213 Copyright 2011 A.M.S. Global Inc. All rights reserved



450369890895

Advanced Performance 28 2STS 64LC

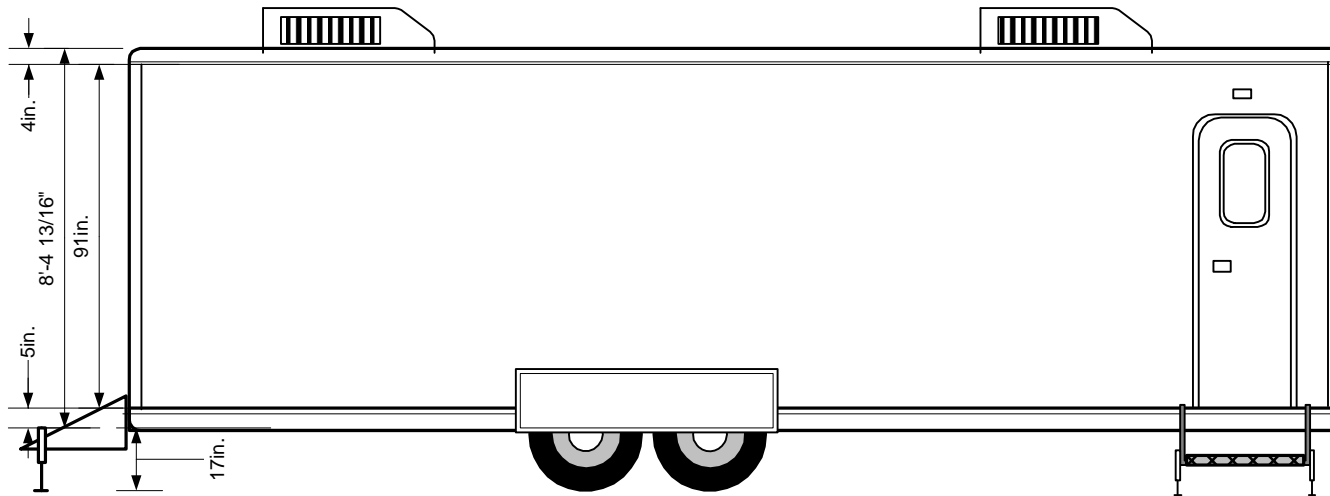

- 64 15x12x48 Lockers
- 3 one step landings
- leveling jacks
- 2 6000 pound axles with electric brakes
- Air Conditioned 30,000 BTU heat 11000
- 1MB 12 volt CVS Jets Vacuerator Pump
- (1) 240 v @ 50 amp AC power required
- Heat on demand metered showers & faucets
- All metal and composite construction
- 2 Jets Marine Vacuerator Toilets 2 wall sinks
- Optima glass mat battery
- Direct connect to sewer
- Uses a pint of water per flush
- LED 50,000 hour burn lighting
- Radiused skylight doors and auto closers
- Liquefies all waste and paper
- Self Pumping to Sewer Tap
- over 100 feet w/10' head
- Retractable tongue

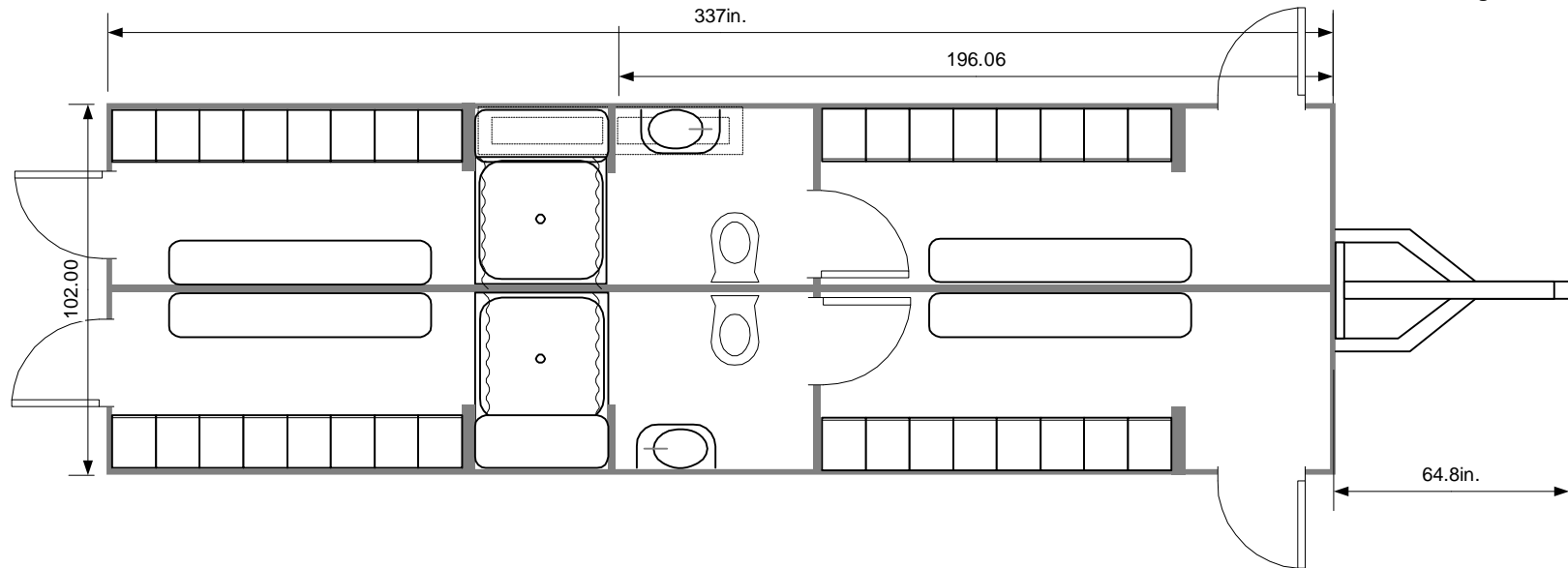

This document is the property of and contains unpublished proprietary information and trade secrets of A.M.S. Global Inc. By accepting possession of the document the recipient agrees to make no copies transcriptions or any use of this document or the information contained herein except as authorized by A.M.S. Global Inc. and further agrees to safe keep this document and return it to A.M.S. Global Inc. upon demand.

Approved by _____

www.AMSglobal.us (877) 789-1213 Copyright 2011 A.M.S. Global Inc. All rights reserved



250914490334

Advanced Performance 28 2TS 15SLC

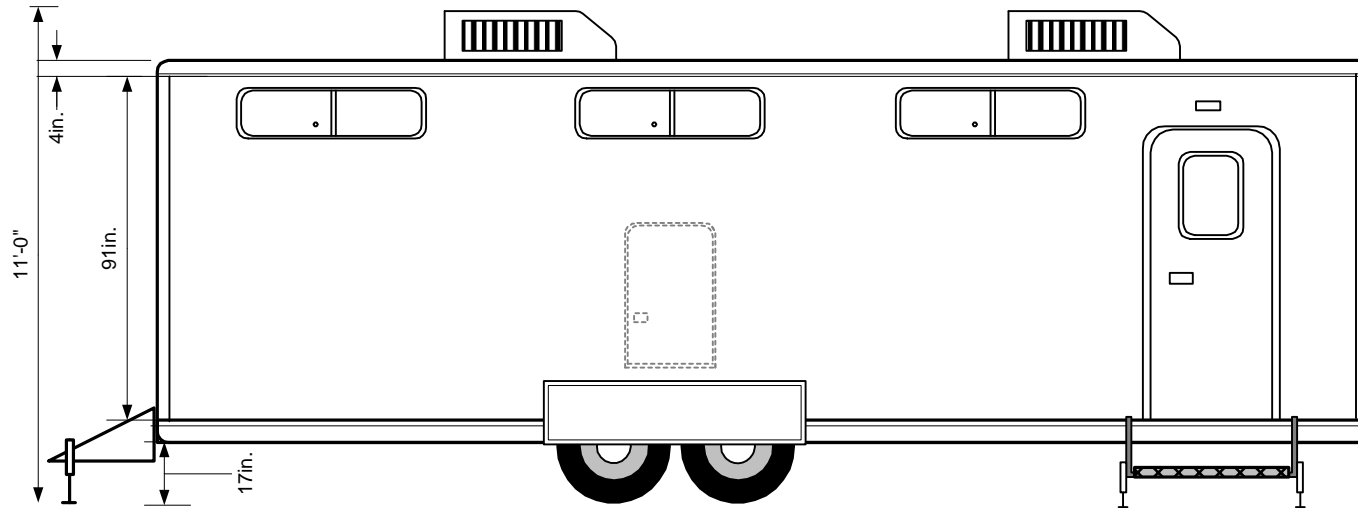

- 15 24x18x72 Lockers W/Footlocker seat
- 2 one step landings with Led porch lights
- Leveling jacks and 6 windows
- 2 7000 pound axles with electric brakes
- Air Conditioned 30,000 BTU heat 11000 btu
- (1) 240 v @ 50 amp AC power required
- Electric Heat on demand metered showers (2)
- All metal and composite construction no wood
- 2 Toilets 2 showers
- Direct connect to sewer
- LED 50,000 hour burn lighting
- Radiused skylight doors and auto closers
- Retractable tongue & Low profile

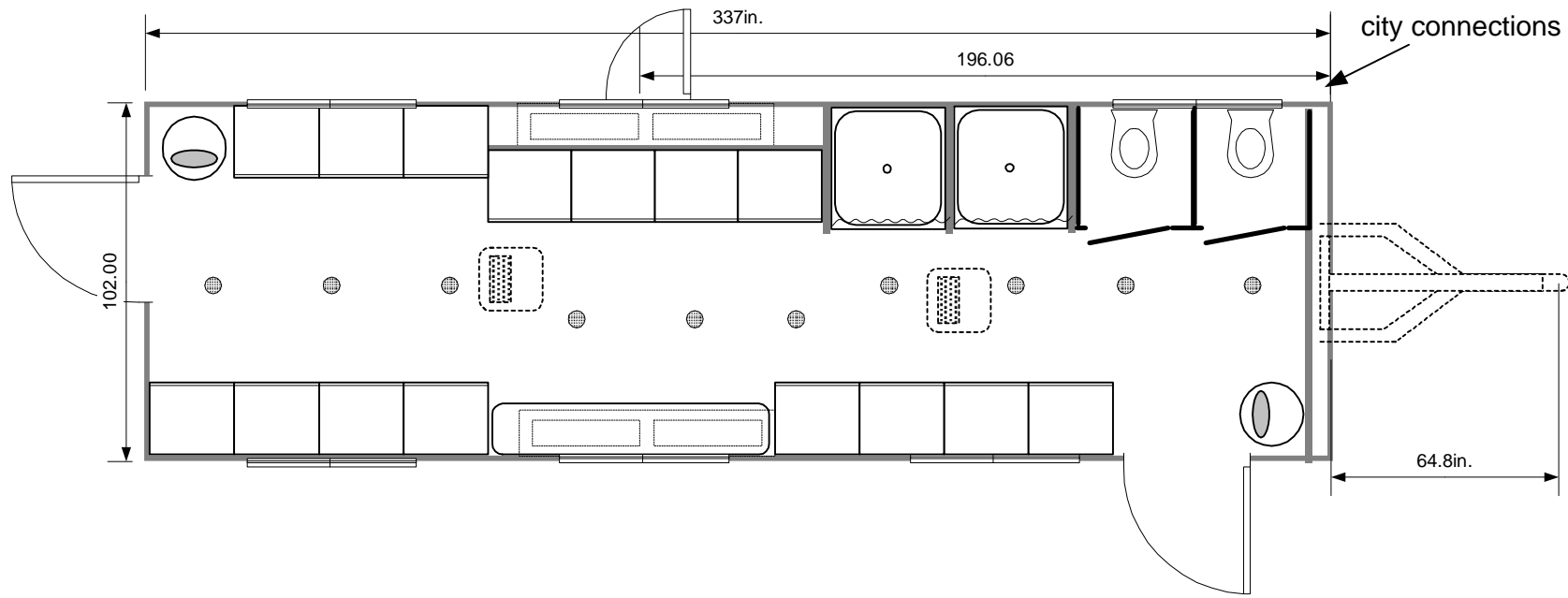

This document is the property of and contains unpublished proprietary information and trade secrets of A.M.S. Global Inc. By accepting possession of the document the recipient agrees to make no copies transcriptions or any use of this document or the information contained herein except as authorized by A.M.S. Global Inc. and further agrees to safe keep this document and return in to A.M.S. Global Inc. upon demand.

Approved by _____

www.AMSglobal.us (877) 789-1213 Copyright 2011 A.M.S. Global Inc. All rights reserved



250914490334

Advanced Performance 28 2S1T2S 20LC + Office Advanced Performance 24 2S1T2S 16LC

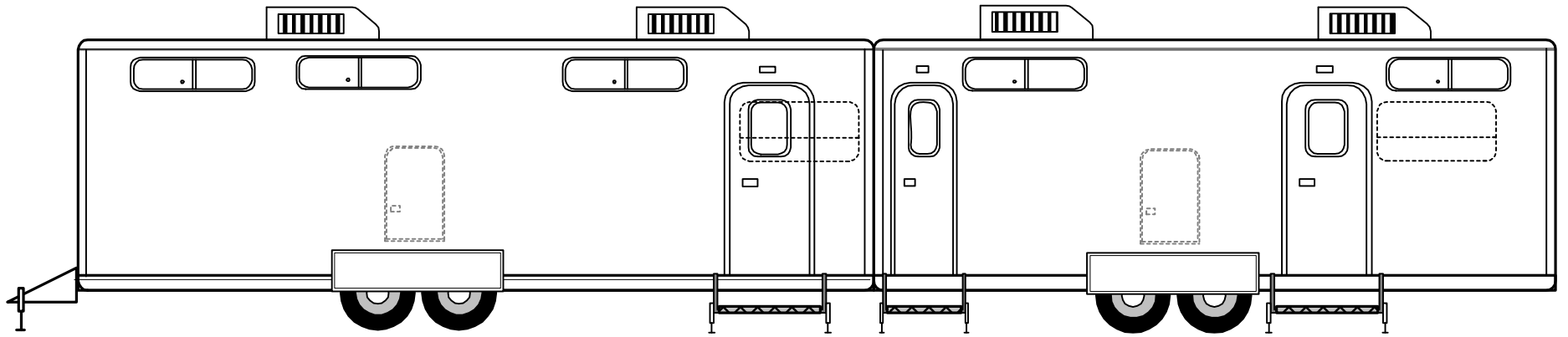

52'

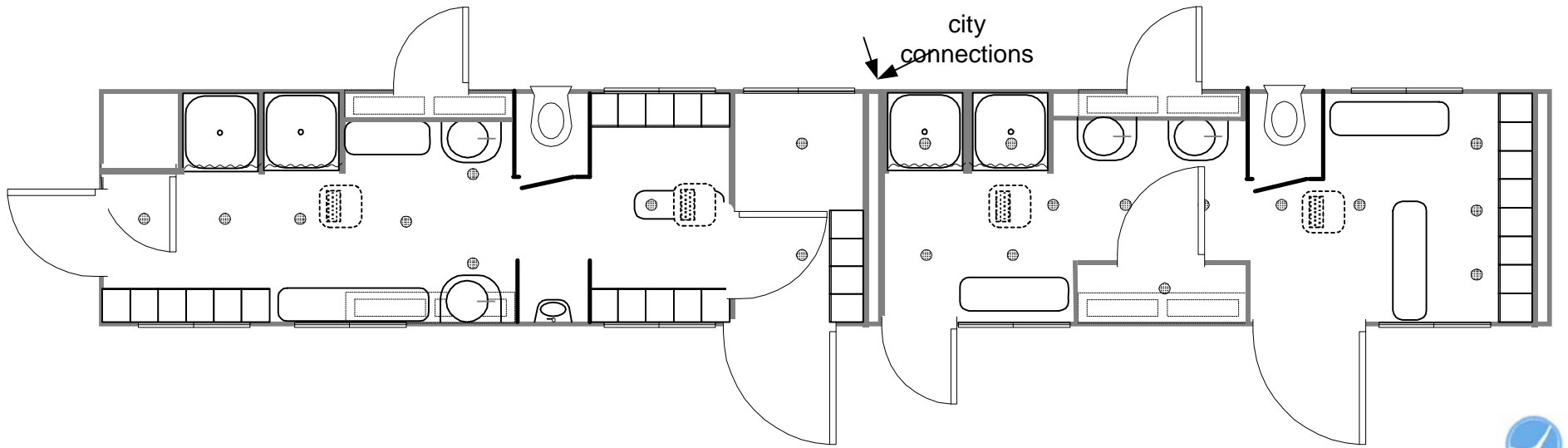

This document is the property of and contains unpublished proprietary information and trade secrets of A.M.S. Global Inc. By accepting possession of this document the recipient agrees to make no copies, transcriptions or any use of this document or the information contained herein except as authorized by A.M.S. Global Inc. and further agrees to safe keep this document and return it to A.M.S. Global Inc. upon demand.

Approved by _____

www.AMSglobal.us (877) 789-1213 Copyright 2011 A.M.S. Global Inc. All rights reserved



24 7 18 54 8 3 2

Advanced Performance 28 4S 20LC

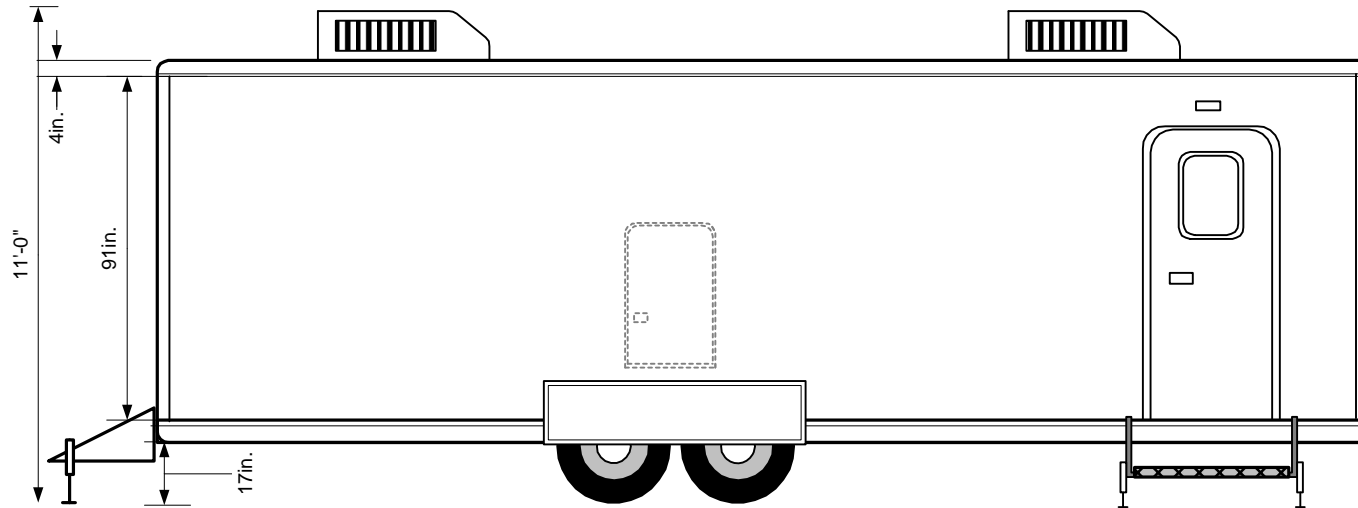

- 20 15x12x36 Lockers
- 2 one step landings with Led porch lights
- leveling jacks front & rear
- 2 7000 pound axles with electric brakes
- 2 15,000 BTU Air with 5500 btu heat each
- 4 powered vents
- 3 1200 watt ceiling heaters
- 240 v @ 245 amp vac power required hard wire
- Heat on demand metered showers (4)
- All metal and composite construction no wood
- Direct connect to sewer
- LED 50,000 hour burn lighting
- Radiused skylight doors and auto closers
- Retractable tongue & Low profile
- Bar sink. cabinets & Skylight doors
- 4 Benches and trash cabinet

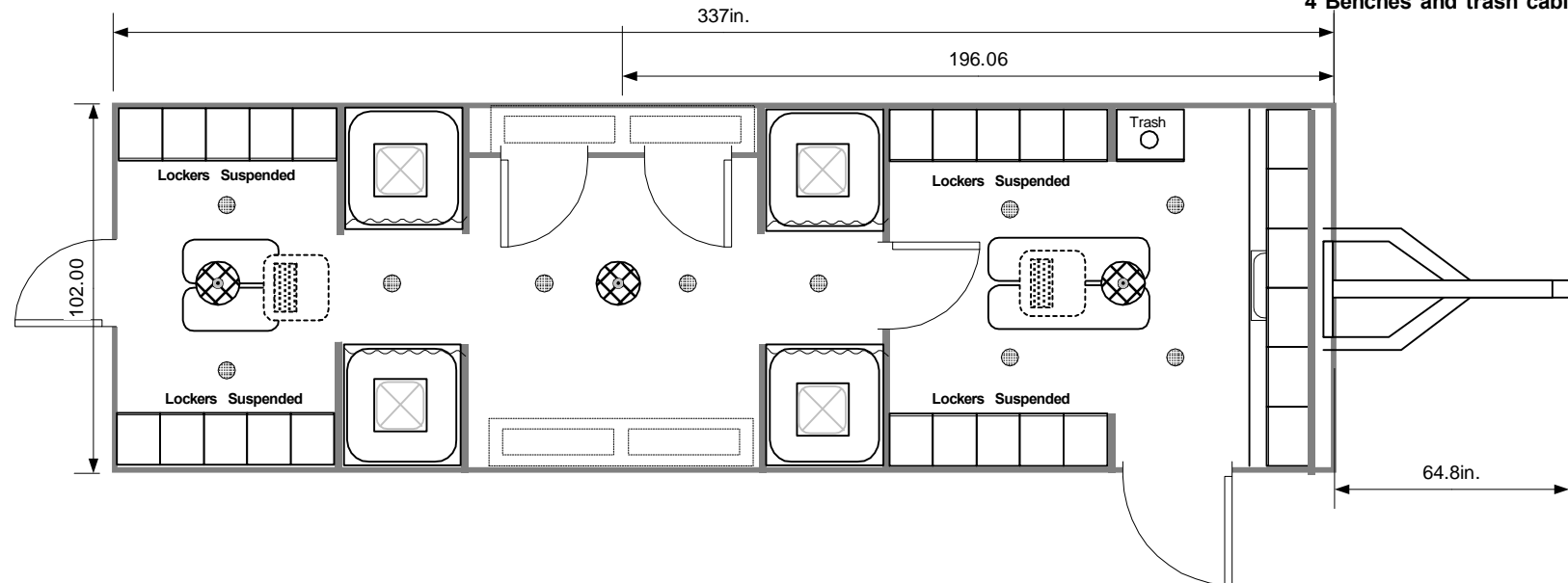

This document is the property of and contains unpublished proprietary information and trade secrets of A.M.S. Global Inc. By accepting possession of this document the recipient agrees to make no copies transcriptions or any use of this document or the information contained herein except as authorized by A.M.S. Global Inc. and further agrees to safe keep this document and return in to A.M.S. Global Inc. upon demand.

Approved by _____

www.AMSglobal.us (877) 789-1213 Copyright 2011 A.M.S. Global Inc. All rights reserved



450369890895

Advanced Performance 28 5STS 20LC

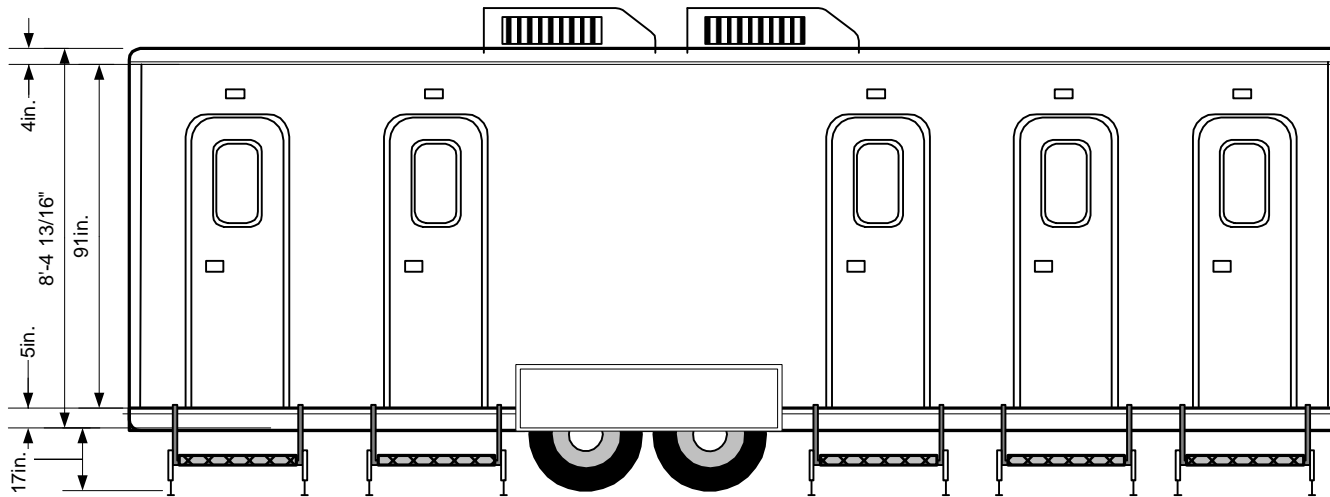

- 20 24x12x48 Lockers
- 5 one step landings
- 2 Remote controlled leveling jacks 16,000 lb
- 2 7000 pound axles with electric brakes
- Air Conditioned 30,000 BTU heat 11000
- 1MB 12 volt CVS Jets Vacumerator Pump
- (1) 240 v @ 50 amp AC power required
- Heat on demand metered showers & faucets
- All metal and composite construction
- 5 Jets™ Marine Toilets & Vacumerator™ 5 sink
- 2 Optima glass mat batteries
- 250 gallon waste tank capacity +- 2000 flushes
- 250 gallon fresh water storage
- Uses less than a quart per flush
- LED 50,000 hour burn lighting
- Radiused skylight doors and auto closers
- Liquefies all waste and paper
- Self Pumping to Sewer Tap
- over 100 feet w/10' head

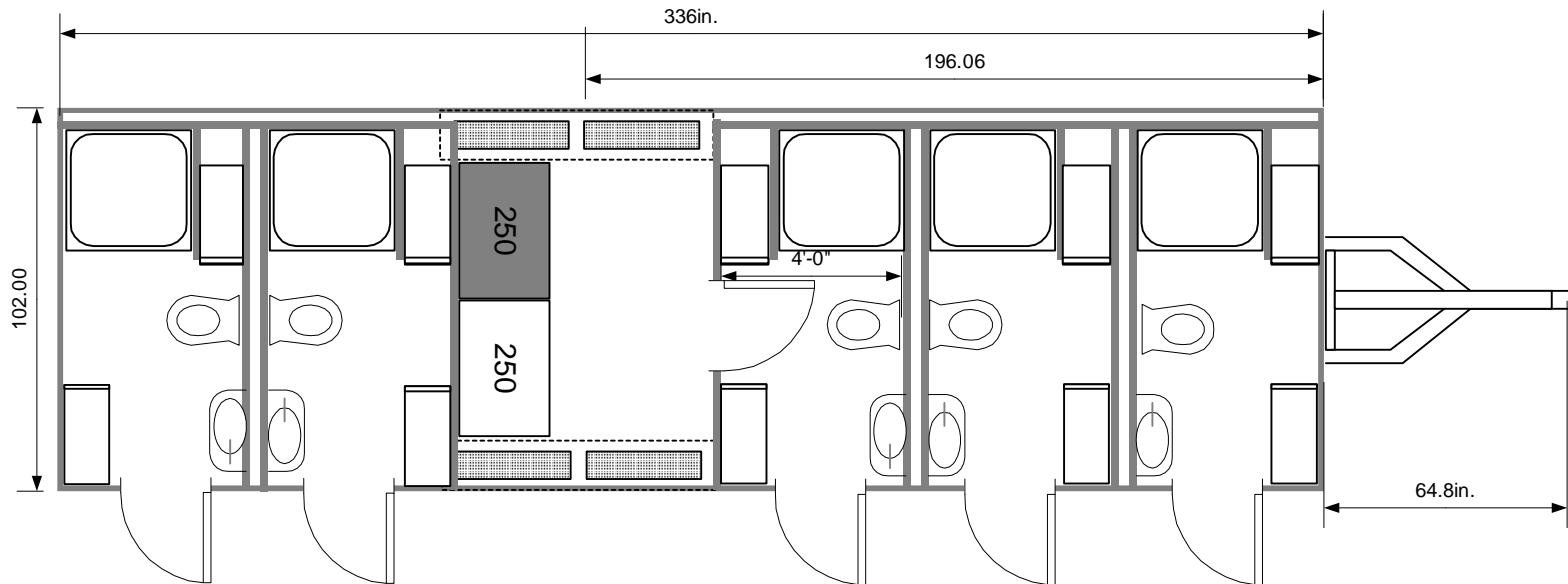

This document is the property of and contains unpublished proprietary information and trade secrets of A.M.S. Global Inc. By accepting possession of this document the recipient agrees to make no copies, transcriptions or any use of this document or the information contained herein except as authorized by A.M.S. Global Inc. and further agrees to safe keep this document and return it to A.M.S. Global Inc. upon demand.

Approved by _____

www.AMSglobal.us (877) 789-1213 Copyright 2011 A.M.S. Global Inc. All rights reserved



26 660 58 959

Advanced Performance 28 4S 20LC

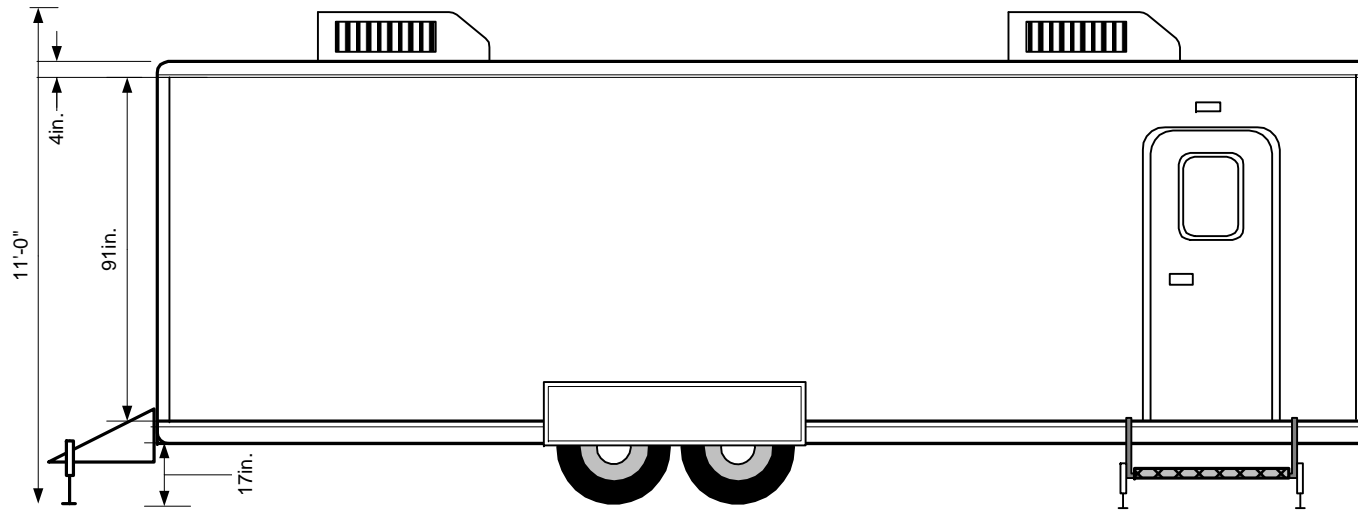

- 20 15x12x36 Lockers
- 2 two step landings with Led porch lights
- manual leveling jacks front & rear
- 2 7000 pound axles with electric brakes
- 2 15,000 BTU Air with 5500 BTU heat each
- 4 Fantastic powered vents
- 2 infrared 18,000 BTU natural gas heaters
- 240 v @ 50 amp vac power required
- Gas Heat on demand metered showers (4)
- All metal and composite construction no wood
- Direct connect to sewer
- LED 50,000 hour burn lighting
- Radiused skylight doors and auto closers
- Retractable tongue & Low profile
- Bar sink, cabinets & Skylight doors
- 5 Benches and trash cabinet

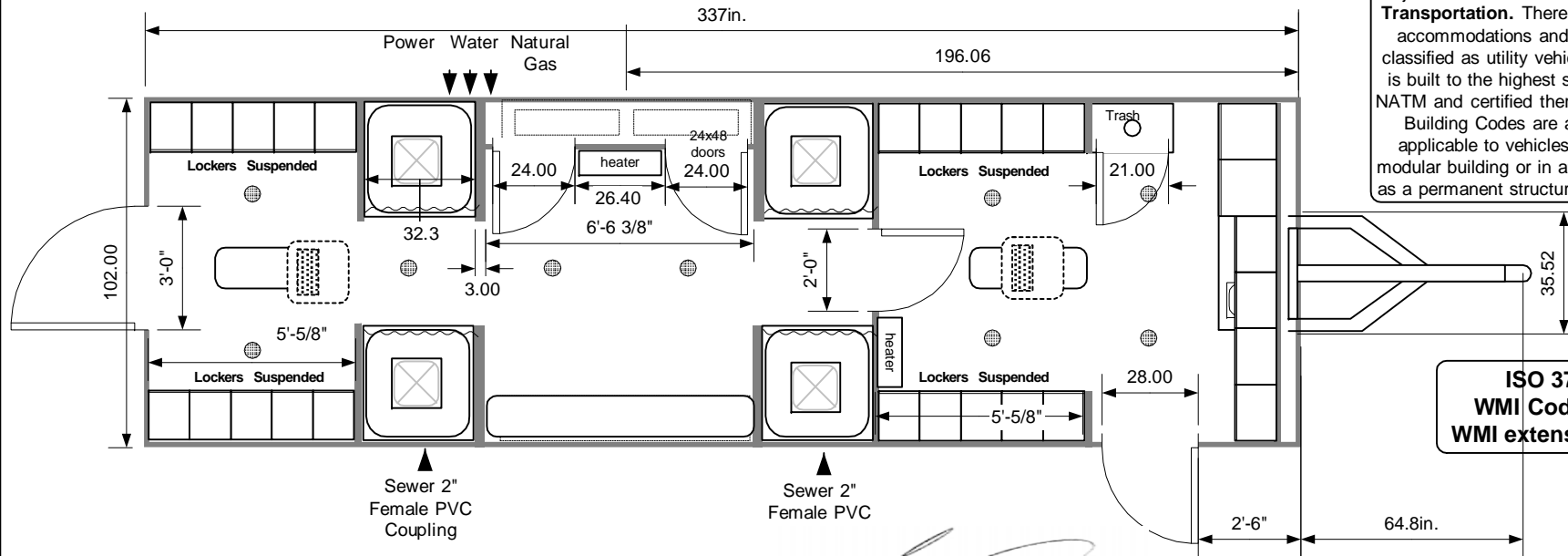

This is a vehicle and falls under the jurisdiction of **The Department of Transportation**. There are no sleeping accommodations and therefore it is classified as utility vehicle. This vehicle is built to the highest standards of the NATM and certified therein. International Building Codes are adhered to as applicable to vehicles. This is not a modular building or in any way designed as a permanent structure. **B11 7851320**

ISO 3780
WMI Code 1A9
WMI extension 898

This document is the property of and contains unpublished proprietary information and trade secrets of A.M.S. Global Inc. By accepting possession of the document the recipient agrees to make no copies, transcriptions or any use of this document or the information contained herein except as authorized by A.M.S. Global Inc. and further agrees to safe keep this document and return it to A.M.S. Global Inc. upon demand.

Approved by 

ID 1A9G1UH27ED898215

www.AMSglobal.us (877) 789-1213 Copyright 2011 A.M.S. Global Inc. All rights reserved



26 660 58 959

Advanced Performance 28 4S 20LC LP

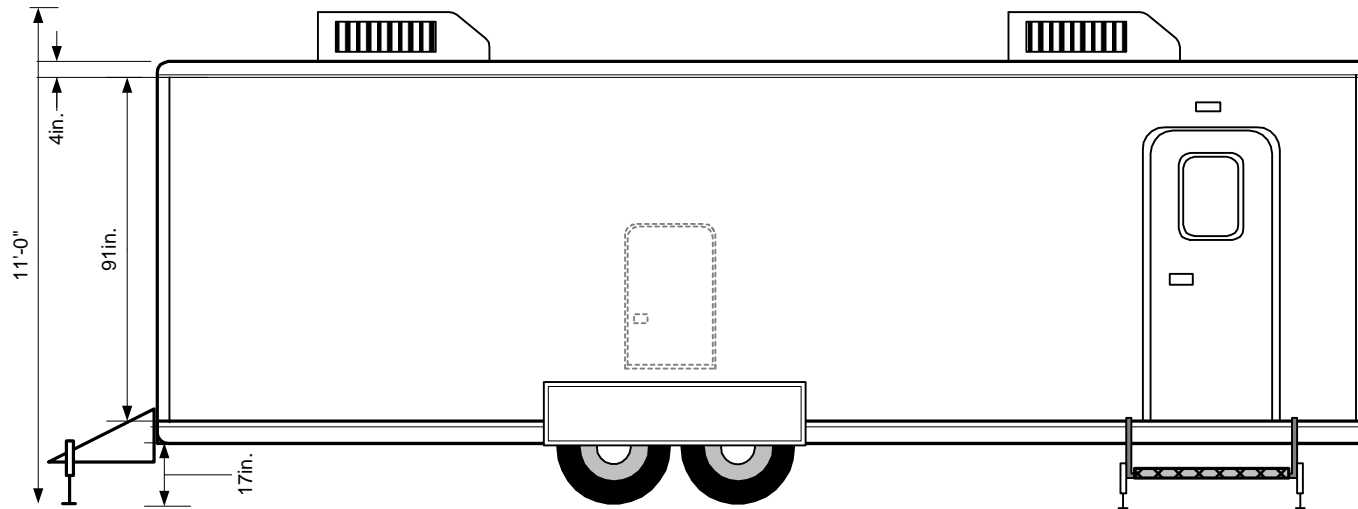

- 20 15x12x36 Lockers
- 2 one step landings with Led porch lights
- leveling jacks front & rear
- 2 7000 pound axles with electric brakes
- 2 15,000 BTU Air with 5500 btu heat each
- 4 powered vents
- 3 1200 watt ceiling heaters
- 240 v @ 50 amp vac power required
- LP Heat on demand metered showers (4)
- Four 40# LP bottles
- All metal and composite construction no wood
- Direct connect to sewer
- LED 50,000 hour burn lighting
- Radiused skylight doors and auto closers
- Retractable tongue & Low profile
- Bar sink. cabinets & Skylight doors
- 5 Benches and trash cabinet

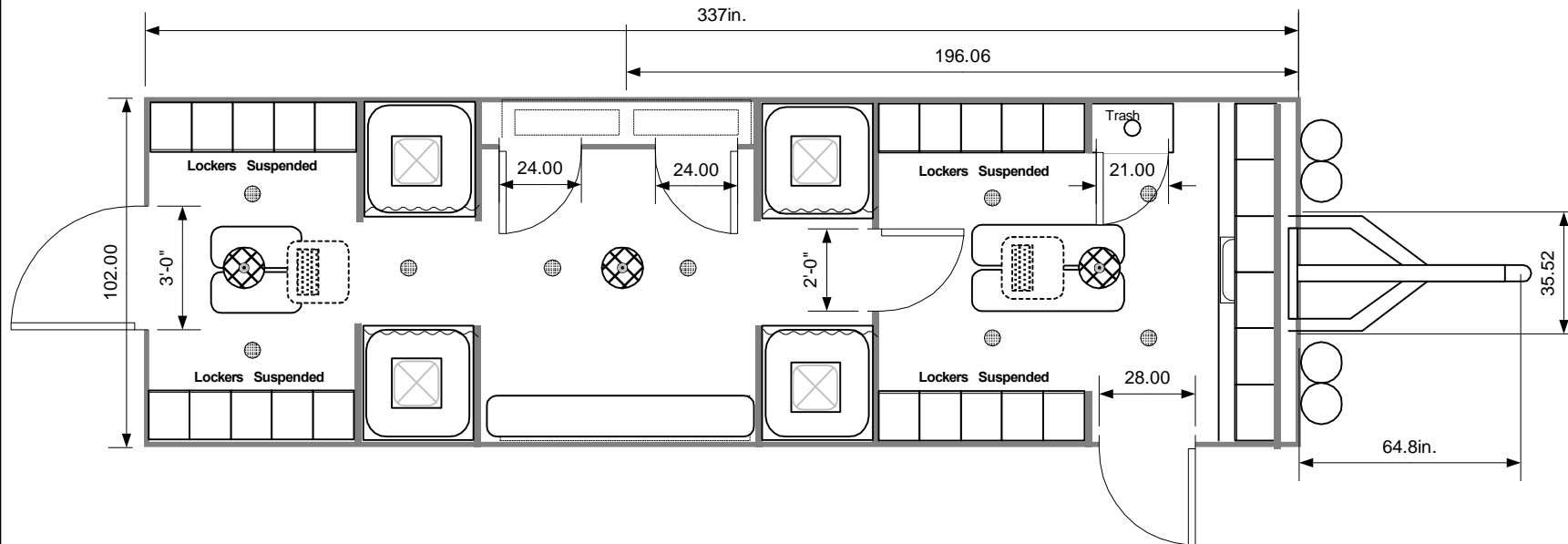

This document is the property of and contains unpublished proprietary information and trade secrets of A.M.S. Global Inc. By accepting possession of the document the recipient agrees to make no copies transcriptions or any use of this document or the information contained herein except as authorized by A.M.S. Global Inc. and further agrees to safe keep this document and return in to A.M.S. Global Inc. upon demand.

Approved by _____

www.AMSglobal.us (877) 789-1213 Copyright 2011 A.M.S. Global Inc. All rights reserved



43011674953

Advanced Performance 30 7STS

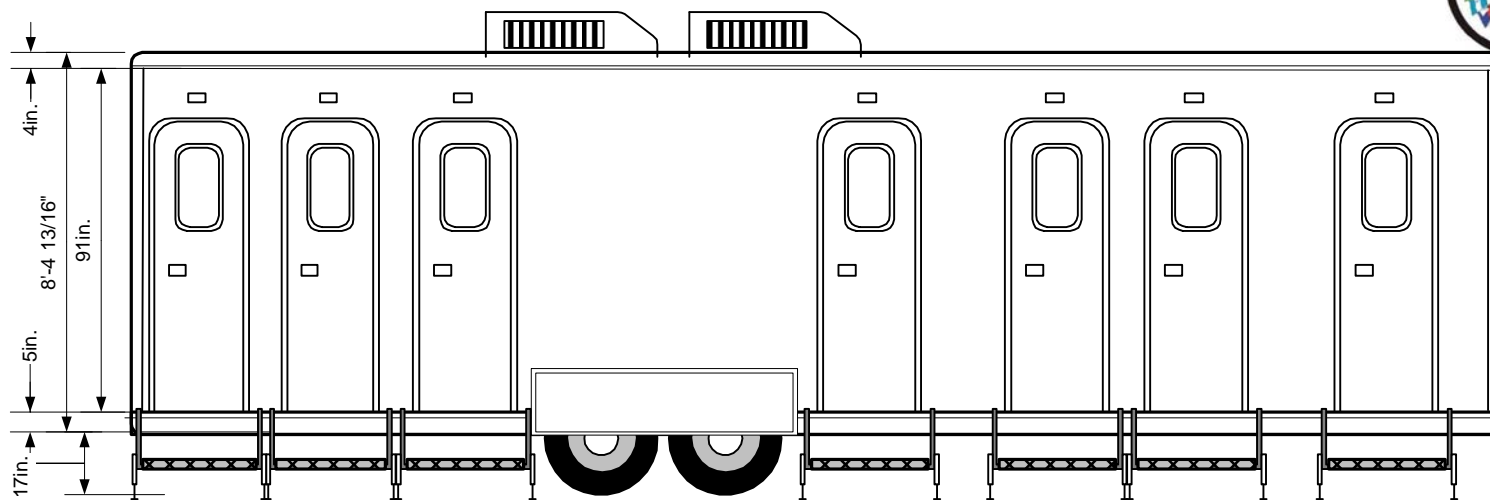

- 7 steps landings
- 2 Remote controlled leveling jacks 16,000 lb
- 2 7000 pound axles with electric brakes
- Air Conditioned 30,000 BTU heat 11000
- 7 1500 watt heaters 7 Fantastic Power vents
- 15MB 240 volt CV S Jet s Vacuumator™ Pump
- (1) 240 v @ 50 amp AC power required
- LP Heat on demand metered showers & faucets
- All metal and composite construction
- 7 Jet s™ Marine Toilets 7 wall sinks
- Stainless steel soap, tissue & towel dispensers
- Optima glass mat battery Retractable tongue
- All metal and composite construction
- 500 gallon waste tank capacity + - 4000 flushes
- 250 gallon freshwater storage
- Uses less than a quart per flush
- LED 50,000 hour burn lighting
- Radiused skylight doors and auto closers
- Liquefies all waste and paper
- Self Pumping to Sewer Tap over 100 feet w/10' head

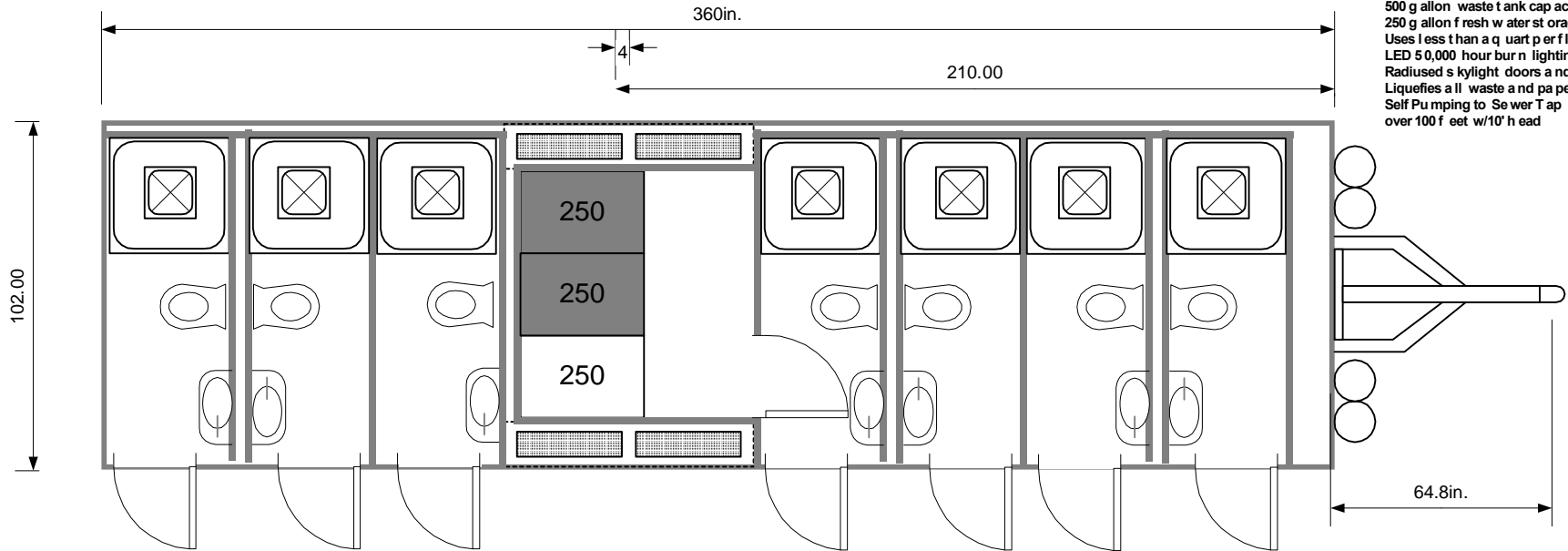

This document is the property of and contains unpublished proprietary information and trade secrets of A.M.S. Global Inc. By accepting possession of the document the recipient agrees to make no copies transcriptions or any use of this document or the information contained herein except as authorized by A.M.S. Global Inc. and further agrees to safe keep this document and return in to A.M.S. Global Inc. upon demand.

Approved by _____

www.AMSglobal.us (877) 789-1213 Copyright 2011 A.M.S. Global Inc. All rights reserved

