

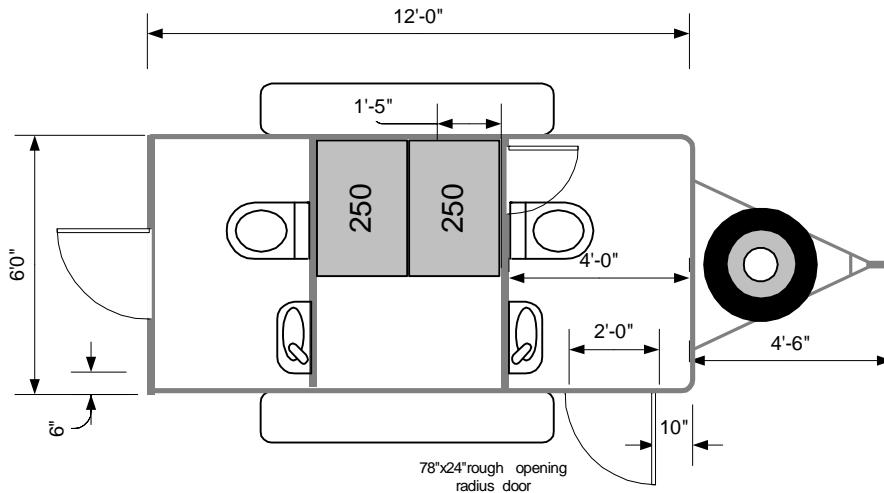

Advanced Performance 12 2ST HD Brute Series

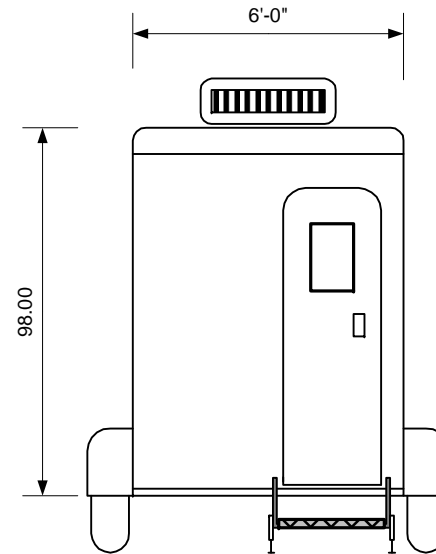

- 2 step landings
- 2 6000 pound axles with electric brakes
- Air Conditioned 15,000 BTU heat 5500
- 10nt 240 volt Jets Vacumerator Pump
- (1) 240 v @ 50 amp AC power required
- metered faucets
- All metal and composite construction
- 2 Jets Marine Vacumerator Toilets 2 wall sinks
- Stainless steel soap,tissue & towel dispensers
- 500 gallon waste tank capacity +- 4000 flushes
- Uses less than a quart per flush
- LED 50,000 hour burn lighting
- Radiused skylight doors and auto closers
- Liquefies all waste and paper
- Self Pumping to Sewer Tap
- over 100 feet w/10' head
- Spare

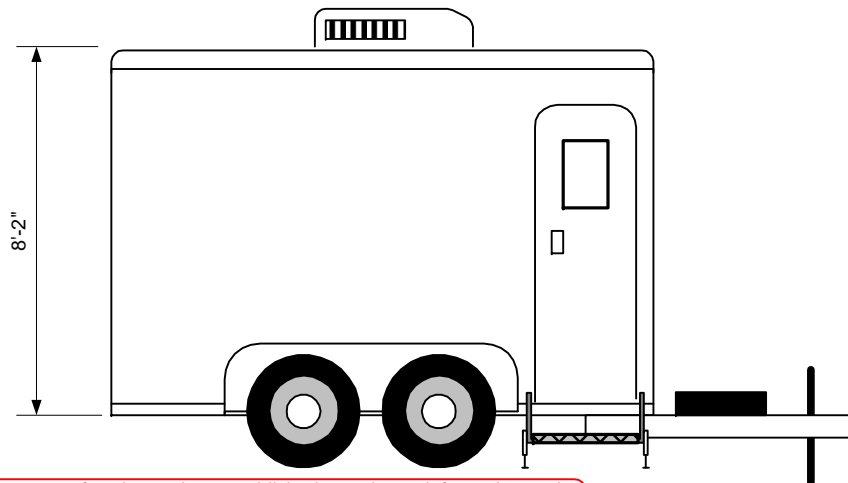

This document is the property of and contains unpublished proprietary information and trade secrets of A.M.S. Global Inc. By accepting possession of the document the recipient agrees to make no copies transcriptions or any use of this document or the information contained herein except as authorized by A.M.S. Global Inc. and further agrees to safe keep this document and return in to A.M.S. Global Inc. upon demand.

Approved by _____





Performance SS-12 Brute Series

13,89422,697

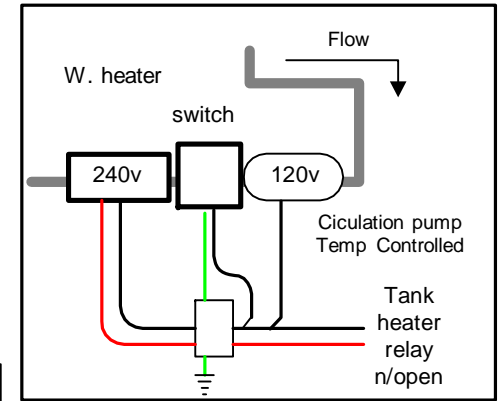
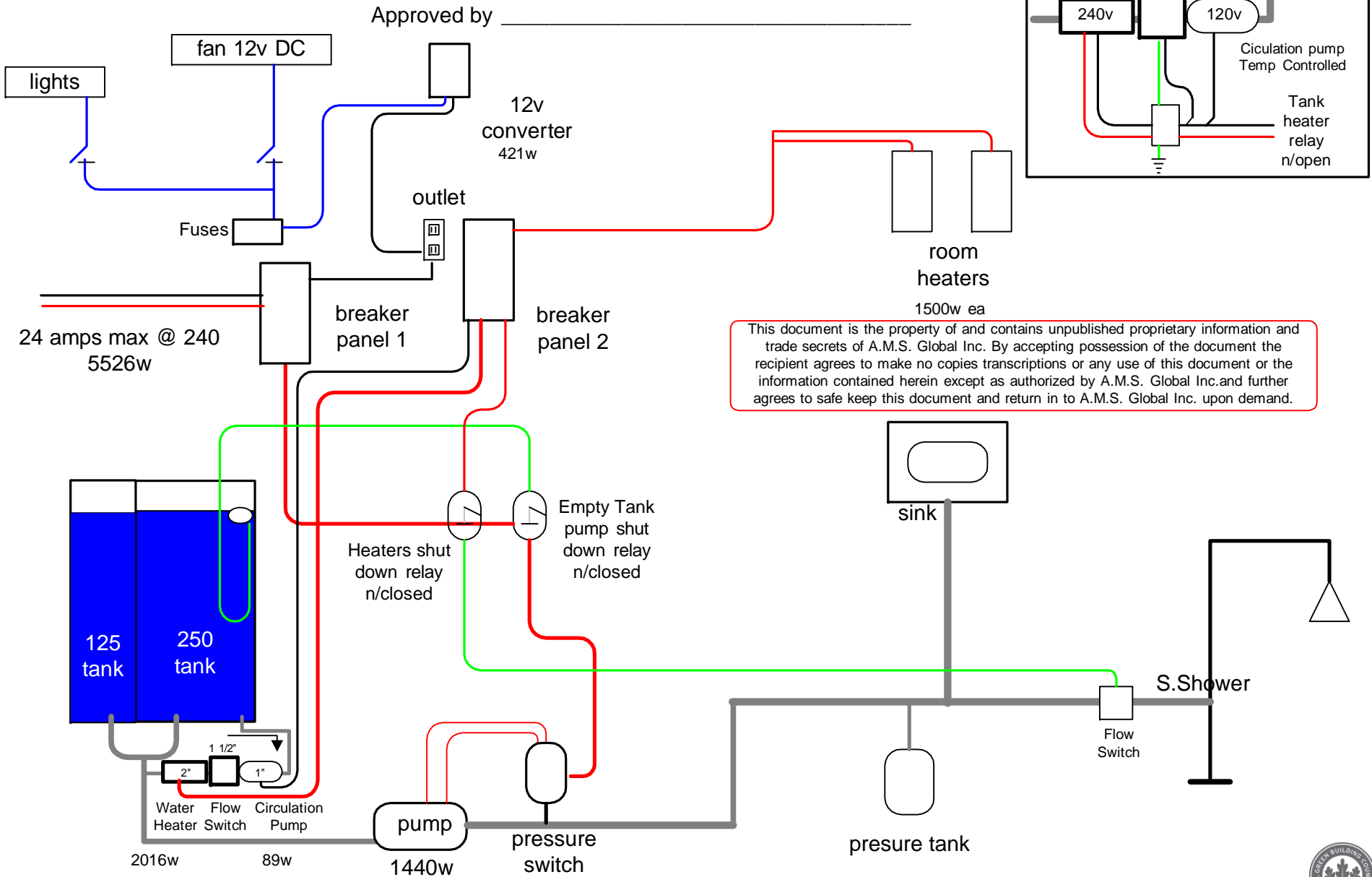

This document is the property of and contains unpublished proprietary information and trade secrets of A.M.S. Global Inc. By accepting possession of the document the recipient agrees to make no copies transcriptions or any use of this document or the information contained herein except as authorized by A.M.S. Global Inc. and further agrees to safe keep this document and return in to A.M.S. Global Inc. upon demand.



13,89422,697



Advanced Performance SS-12 Brute Series

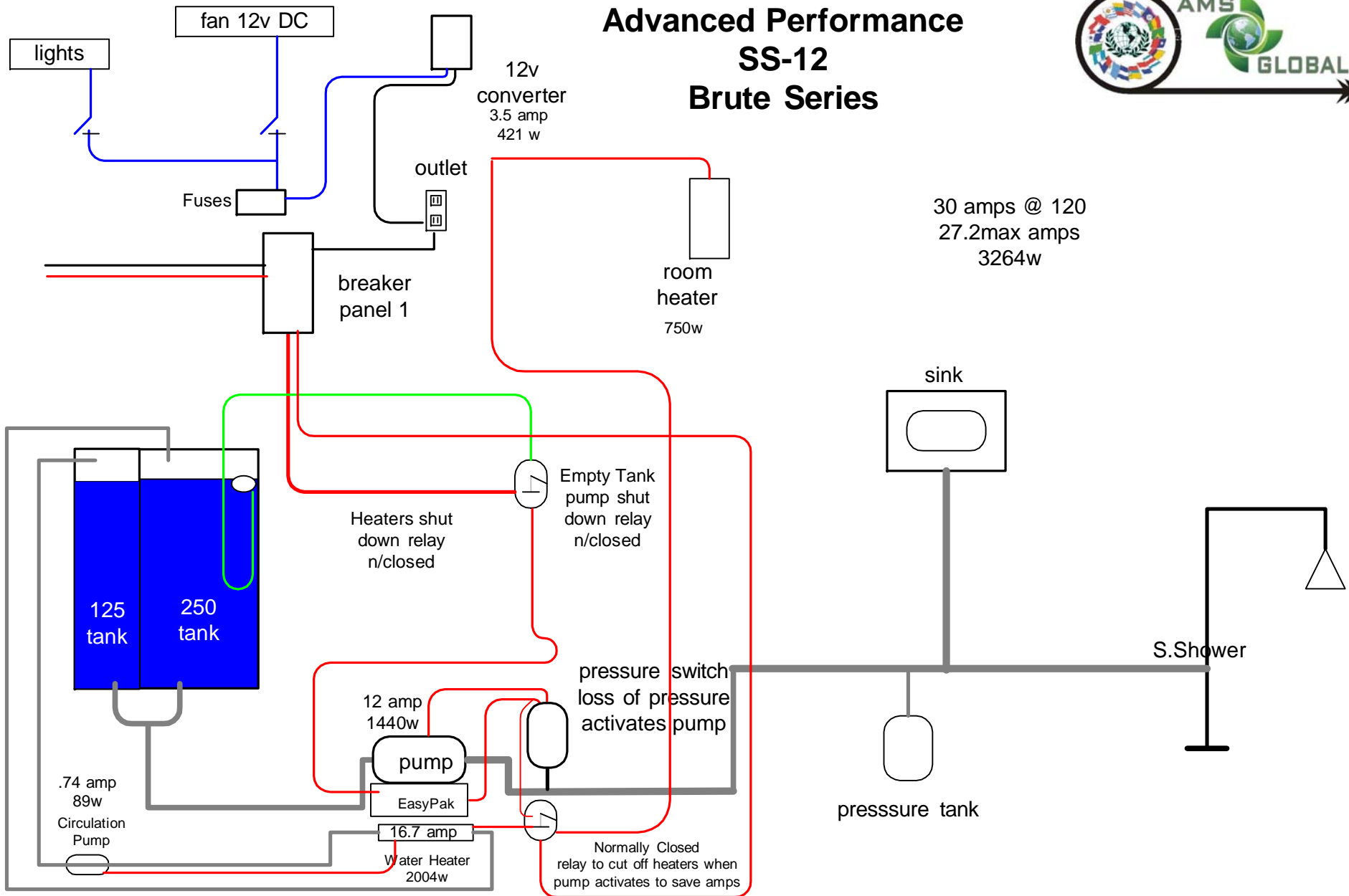

This document is the property of and contains unpublished proprietary information and trade secrets of A.M.S. Global Inc. By accepting possession of the document the recipient agrees to make no copies transcriptions or any use of this document or the information contained herein except as authorized by A.M.S. Global Inc. and further agrees to safe keep this document and return in to A.M.S. Global Inc. upon demand.

Approved by _____

